



RobustFeed U82



Instruction manual

1	SAFETY	4
1.1	Meaning of symbols	4
1.2	Safety precautions	4
1.3	User responsibility	7
1.4	California proposition 65 warning	10
2	INTRODUCTION	11
2.1	Equipment	11
3	TECHNICAL DATA	12
4	INSTALLATION	14
4.1	Lifting instructions	14
5	OPERATION	16
5.1	Recommended maximum current values for connection	17
5.2	Connections and control devices	18
5.3	Cooling liquid connection	19
5.4	Retrofitting an interconnection strain relief kit	19
5.5	Heat kit switch (Offshore versions only)	21
5.6	Starting procedure	21
5.7	Lighting inside the wire feed unit	21
5.8	Bobbin brake	21
5.9	Changing and loading wire	22
5.10	Changing feed rollers	22
5.11	Changing the wire guides	23
5.11.1	Inlet wire guide	23
5.11.2	Middle wire guide	24
5.11.3	Outlet wire guide	24
5.12	Roller pressure	25
5.13	Wear parts storage compartment	27
5.14	Attachment of the wheel kit	27
5.14.1	Attaching the wheels to the wheel kit frame	27
5.14.2	Wire feed unit in vertical position	28
5.14.3	Wire feed unit in horizontal position	28
5.15	Attaching both the wheel kit and the torch strain relief accessory	29
5.16	Marathon Pac™ installation	31
6	CONTROL PANEL	34
6.1	External blank panel	34
6.2	Internal control panel	35
6.3	Setting the gas flow	35
6.4	Rotating the external control panel	36
7	MAINTENANCE	37
7.1	Inspection, cleaning and replacement	37
8	TROUBLESHOOTING	38
9	ORDERING SPARE PARTS	39
10	ASSEMBLY INSTRUCTIONS	40
	WIRING DIAGRAM	41
	ORDERING NUMBERS	43
	WEAR PARTS	44

ACCESSORIES 46

1 SAFETY

1.1 Meaning of symbols

As used throughout this manual: Means Attention! Be Alert!



DANGER!

Means immediate hazards which, if not avoided, will result in immediate, serious personal injury or loss of life.



WARNING!

Means potential hazards which could result in personal injury or loss of life.



CAUTION!

Means hazards which could result in minor personal injury.



WARNING!

Before use, read and understand the instruction manual and follow all labels, employer's safety practices and Safety Data Sheets (SDSs).



1.2 Safety precautions



WARNING!

These Safety Precautions are for your protection. They summarize precautionary information from the references listed in the Additional Safety Information section. Before performing any installation or operating procedures, be sure to read and follow the safety precautions listed below as well as all other manuals, material safety data sheets, labels, etc. Failure to observe Safety Precautions can result in injury or death.



PROTECT YOURSELF AND OTHERS

Some welding, cutting and gouging processes are noisy and require ear protection. The arc, like the sun, emits ultraviolet (UV) and other radiation and can injure the skin and eyes. Hot metal can cause burns. Training in the proper use of the processes and equipment is essential to prevent accidents. Therefore:

1. Wear a welding helmet fitted with a proper shade of filter to protect your face and eyes when welding or watching.
2. Always wear safety glasses with side shields in any work area, even if welding helmets, face shields and goggles are also required.
3. Use a face shield fitted with the correct filter and cover plates to protect your eyes, face, neck and ears from sparks and rays of the arc when operating or observing operations. Warn bystanders not to look at the arc and not to expose themselves to the rays of the electric-arc or hot metal.
4. Wear flameproof gauntlet-type gloves, heavy long-sleeve shirt, cuffless pants, high-topped shoes, and a welding helmet or cap for protection, to protect against arc rays and hot sparks or hot metal. A flameproof apron may also be desirable as protection against radiated heat and sparks.
5. Hot sparks or metal can lodge in rolled up sleeves, trouser cuffs, or pockets. Sleeves and collars should be kept buttoned and open pockets eliminated from the front of the clothing.
6. Protect other personnel from arc rays and hot sparks with a suitable non-flammable partition or curtains.
7. Use goggles over safety glasses when chipping slag or grinding. Chipped slag may be hot and can fly for long distances. Bystanders should also wear goggles over safety glasses.



FIRES AND EXPLOSIONS

Heat from flames and arcs can start fires. Hot slag or sparks can also cause fires and explosions. Therefore:

1. Protect yourself and others from flying sparks and hot metal.
2. Move all combustible materials well away from the work area or cover the materials with a protective non-flammable covering. Combustible materials include wood, cloth, sawdust, liquid and gas fuels, solvents, paints, and coating paper, etc.
3. Hot sparks or hot metal can fall through cracks or crevices in floors or wall openings and cause a hidden smoldering fire or fires on the floor below. Make certain that such openings are protected from hot sparks and metal.
4. Do not weld, cut, or perform other hot work until the work piece has been completely cleaned so that there are no substances on the work piece which might produce flammable or toxic vapors. Do not perform hot work on closed containers, they may explode.
5. Have fire extinguishing equipment handy for instant use, such as a garden hose, water pail, sand bucket, or portable fire extinguisher. Be sure you are trained in its use.
6. Do not use equipment beyond its ratings. For example, an overloaded welding cable can overheat and create a fire hazard.
7. After completing work, inspect the work area to make sure there are no hot sparks or hot metal that could cause a fire later. Use fire watchers when necessary.



ELECTRICAL SHOCK

Contact with live electrical parts and ground can cause severe injury or death. DO NOT use AC welding current in damp areas, if movement is confined, or if there is danger of falling. Therefore:

1. Be sure the power source frame (chassis) is connected to the earth system of the input power.
2. Connect the workpiece to a good electrical earth.
3. Connect the work cable to the workpiece. A poor or missing connection can expose you or others to a fatal shock.
4. Use well-maintained equipment. Replace worn or damaged cables.
5. Keep everything dry, including clothing, work area, cables, torch/electrode holder and power source.
6. Make sure that all parts of your body are insulated from both the work piece and from the ground.
7. Do not stand directly on metal or the ground while working in tight quarters or a damp area; stand on dry boards or an insulating platform and wear rubber-soled shoes.
8. Put on dry, hole-free gloves before turning on the power.
9. Turn off the power, before removing your gloves.
10. Refer to ANSI/ASC Standard Z49.1 for specific grounding recommendations. Do not mistake the work lead for a earth cable.



ELECTRIC AND MAGNETIC FIELDS

May be dangerous. Electric current flowing through any conductor causes localized Electric and Magnetic Fields (EMF). Welding and cutting current creates EMF around welding cables and welding machines. Therefore:

1. Welders with pacemakers fitted should consult their doctor before welding. EMF may interfere with some pacemakers.
2. Exposure to EMF may have other health effects which are unknown.

3. Welders should use the following procedures to minimize exposure to EMF:
 - a) Route the electrode and work cables together. Secure them with tape when possible.
 - b) Never coil the torch or work cable around your body.
 - c) Do not place your body between the torch and work cables. Route cables on the same side of your body.
 - d) Connect the work cable to the workpiece as close as possible to the area being welded.
 - e) Keep the welding power source and cables as far away from your body as possible.



FUMES AND GASES

Fumes and gases, can cause discomfort or harm, particularly in confined spaces. Shielding gases can cause asphyxiation. Therefore:

1. Keep your head out of the fumes. Do not breathe the fumes and gases.
2. Always provide adequate ventilation in the work area by natural or mechanical means. Do not weld, cut or gouge on materials such as galvanized steel, stainless steel, copper, zinc, lead beryllium or cadmium unless positive mechanical ventilation is provided. Do not breathe in the fumes from these materials.
3. Do not operate near degreasing and spraying operations. The heat or arc can react with chlorinated hydrocarbon vapors to form phosgene, a highly toxic gas, and other irritant gases.
4. If you develop momentary eye, nose or throat irritation while operating, this is an indication that the ventilation is not adequate. Stop work and take the necessary steps to improve ventilation in the work area. Do not continue to operate if physical discomfort persists.
5. Refer to ANSI/ASC Standard Z49.1 for specific ventilation recommendations.



CYLINDER HANDLING

Cylinders, if mishandled, can rupture and violently release gas. A sudden rupture of cylinder valve or relief device can injure or kill. Therefore:

1. Locate cylinders away from heat, sparks and flames. Never strike an arc on a cylinder.
2. Use the proper gas for the process and use the proper pressure reducing regulator designed to operate from the compressed gas cylinder. Do not use adapters. Maintain hoses and fittings in good condition. Follow the manufacturer's operating instructions for mounting a regulator to a compressed gas cylinder.
3. Always secure cylinders in an upright position, by chain or strap, to suitable hand trucks, undercarriages, benches, wall, post or racks. Never secure cylinders to work tables or fixtures where they may become part of an electrical circuit.
4. When not in use, keep cylinder valves closed. Have valve protection cap in place if regulator is not connected. Secure and move cylinders by using suitable hand trucks.



MOVING PARTS

Moving parts, such as fans, rotors and belts can cause injury. Therefore:

1. Keep all doors, panels, guards, and covers closed and securely in place.
2. Have only qualified people remove covers for maintenance and troubleshooting as necessary
3. Keep hands, hair, loose clothing and tools away from moving parts.
4. Reinstall panels or covers and close doors when service is finished and before starting the unit.

**WARNING!
FALLING EQUIPMENT CAN INJURE**

- Only use lifting eye to lift unit. Do NOT use running gear, gas cylinders or any other accessories.
- Use equipment of adequate capacity to lift and support unit.
- If using lift forks to move unit, be sure forks are long enough to extend beyond opposite side of unit.
- Keep cables and cords away from moving vehicles when working from an aerial location.

**WARNING!
EQUIPMENT MAINTENANCE**

Faulty or improperly maintained equipment can cause injury or death. Therefore:

1. Always have qualified personnel perform the installation, troubleshooting and maintenance work. Do not perform any electrical work unless you are qualified to perform such work.
2. Before performing any maintenance work inside a power source, disconnect the power source from the incoming electrical power.
3. Maintain cables, earthing wire, connections, power cord and power supply in safe working order. Do not operate any equipment in faulty condition.
4. Do not abuse any equipment or accessories. Keep equipment away from heat sources such as furnaces, wet conditions such as water puddles, oil or grease, corrosive atmospheres and inclement weather.
5. Keep all safety devices and cabinet covers in position and in good repair.
6. Use equipment only for its intended purpose. Do not modify it in any manner.

**CAUTION!
ADDITIONAL SAFETY INFORMATION**

For more information on safe practices for electric arc welding and cutting equipment, ask your supplier for a copy of "Precautions and Safe Practices for Arc Welding, Cutting and Gouging," Form 52-529.

The following publications are recommended:

- ANSI/ASC Z49.1 - "Safety in Welding and Cutting"
- AWS C5.5 - "Recommended Practices for Gas Tungsten Arc Welding"
- AWS C5.6 - "Recommended Practices for Gas Metal Arc welding"
- AWS SP - "Safe practices" - Reprint, Welding Handbook
- ANSI/AWS F4.1 - "Recommended Safe Practices for Welding and Cutting of Containers That Have Held Hazardous Substances"
- OSHA 29 CFR 1910 - "Safety and health standards"
- CSA W117.2 - "Code for safety in welding and cutting"
- NFPA Standard 51B, "Fire Prevention During Welding, Cutting, and Other Hot Work"
- CGA Standard P-1, "Precautions for Safe Handling of Compressed Gases in Cylinders"
- ANSI Z87.1, "Occupational and Educational Personal Eye and Face Protection Devices"

1.3 User responsibility

Users of ESAB equipment have the ultimate responsibility for ensuring that anyone who works on or near the equipment observes all the relevant safety precautions. Safety precautions must meet the requirements that apply to this type of equipment. The following recommendations should be observed, in addition to the standard regulations that apply to the workplace.

All work must be carried out by trained personnel well-acquainted with the operation of the equipment. Incorrect operation of the equipment may lead to hazardous situations, which could result in injury to the operator and damage to the equipment.

1. Anyone who uses the equipment must be familiar with:
 - its operation
 - the location of emergency stops
 - its function
 - the relevant safety precautions
 - welding and cutting or other applicable operation of the equipment
2. The operator must ensure that:
 - no unauthorized person is within the working area of the equipment when it is started up
 - no-one is unprotected when the arc is struck or work is started with the equipment
3. The workplace must:
 - be suitable for the purpose
 - be free from drafts
4. Personal safety equipment:
 - Always wear recommended personal safety equipment, such as safety glasses, flame-proof clothing, safety gloves
 - Do not wear loose-fitting items, such as scarves, bracelets, rings, etc., which could become trapped or cause burns
5. General precautions:
 - Make sure the return cable is connected securely
 - Work on high voltage equipment **may only be carried out by a qualified electrician**
 - Appropriate fire extinguishing equipment must be clearly marked and close at hand
 - Lubrication and maintenance must **not** be carried out on the equipment during operation



WARNING!

Wire feeders are intended to be used in GMAW (MIG/MAG) mode only.

If used in any other welding mode, such as SMAW (MMA), the welding cable between wire feeder and power source must be disconnected, or else the wire feeder becomes live or energized.

If equipped with ESAB cooler

Use ESAB approved coolant only. Non-approved coolant might damage the equipment and jeopardize product safety. In case of such damage, all warranty undertakings from ESAB cease to apply.

Recommended ESAB coolant ordering number: 0465 720 002.

For ordering information, see the "ACCESSORIES" chapter in the instruction manual.



WARNING!

Arc welding and cutting may cause injury to yourself and others. Take precautions when welding and cutting.

**ELECTRIC SHOCK - Can kill**

- Do not touch live electrical parts or electrodes with bare skin, wet gloves, or wet clothing
- Insulate yourself from work and ground.
- Ensure your working position is safe

**ELECTRIC AND MAGNETIC FIELDS - Can be dangerous to health**

- Welders with pacemakers fitted should consult their doctor before welding. EMF may interfere with some pacemakers.
- Exposure to EMF may have other health effects which are unknown.
- Welders should use the following procedures to minimize exposure to EMF:
 - Route the electrode and work cables together on the same side of your body. Secure them with tape when possible. Do not place your body between the torch and work cables. Never coil the torch or work cable around your body. Keep the welding power source and cables as far away from your body as possible.
 - Connect the work cable to the workpiece as close as possible to the area being welded.

**FUMES AND GASES - Can be dangerous to health**

- Keep your head out of the fumes
- Use ventilation, extraction at the arc, or both, to take fumes and gases away from your breathing zone and the general area

**ARC RAYS - Can injure eyes and burn skin**

- Protect your eyes and body. Use the correct welding screen and filter lens and wear protective clothing
- Protect bystanders with suitable screens or curtains

**NOISE - Excessive noise can damage hearing**

Protect your ears. Use ear defenders or other hearing protection.

**MOVING PARTS - Can cause injuries**

- Keep all doors, panels and covers closed and securely in place. Have only qualified people remove covers for maintenance and troubleshooting as necessary. Reinstall panels or covers and close doors when service is finished and before starting engine.



- Stop engine before installing or connecting unit.
- Keep hands, hair, loose clothing and tools away from moving parts.

**FIRE HAZARD**

- Sparks (spatter) can cause a fire. Therefore, make sure that there are no inflammable materials nearby
- Do not use on closed containers.

**HOT SURFACE - Parts can burn**

- Do not touch parts bare handed.
- Allow cooling period before working on equipment.
- To handle hot parts, use proper tools and/or insulated welding gloves to prevent burns.

MALFUNCTION - Call for expert assistance in the event of malfunction.

PROTECT YOURSELF AND OTHERS!



CAUTION!

This product is solely intended for arc welding.

ESAB has an assortment of welding accessories and personal protection equipment for purchase. For ordering information contact your local ESAB dealer or visit us on our website.

1.4 California proposition 65 warning



WARNING!

Welding or cutting equipment produces fumes or gases which contain chemicals known in the State of California to cause birth defects and, in some cases, cancer. (California Health & Safety Code Section 25249.5 et seq.)



WARNING!

This product can expose you to chemicals including lead, which are known to the state of California to cause cancer and birth defects or other reproductive harm. Wash hands after use.

For more information, go to www.P65Warnings.ca.gov.

2 INTRODUCTION

The RobustFeed equipped with a U8₂ control panel is intended for GMAW welding together with 400 A, 500 A and 600 A CAN-based welding power sources.

The wire feed unit comes in different versions (see the "ORDERING NUMBERS" appendix).



NOTE!

Wire feed unit variants equipped with ESAB Logic Pump (ELP) is intended to be used together with welding power sources equipped with ELP. For further information about ELP, see the "Cooling liquid connection" section.

The wire feed units are sealed and contain four-wheel drive wire feed mechanisms as well as control electronics.

It can be used together with standard Ø 200 mm and Ø 300 mm wire bobbin or with ESAB's Marathon Pac™ with a wire adapter to feed the wire.

The wire feed unit can be placed on a trolley, suspended above the workplace or on the floor (standing up or laying down and with or without a wheel set).

ESAB accessories for the product can be found in the "ACCESSORIES" chapter of this manual.

2.1 Equipment

The wire feed unit is supplied with:

- Instruction manual - Wire feed unit
- Instruction manual - Control panel
- Quick start guide
- A USB with a multilingual instruction manual for the U8₂ and U8₂ Plus with holding bracket (not included in U0 variant).
- Drive rolls: 0.9/1.0 mm (0.040 in.) / 1.2 mm (0.045 in.)
- Wire guides: 0.6–1.6 mm (0.023–1/16 in.)

Instruction manuals in other languages can be downloaded from the Internet: manuals.esab.com

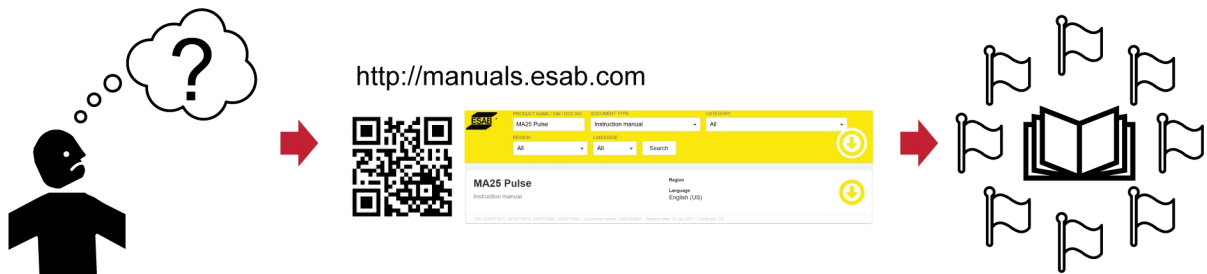

3 TECHNICAL DATA

RobustFeed U8₂	
Power Supply voltage	42 V AC, 50–60 Hz
Power requirement	181 VA
Rated supply current I₁	4.3 A
Settings data:	
Wire feed speed	32–984 in./min (0.8–25.0 m/min)
Torch connection	EURO, Tweco 4
Max. diameter wire bobbin	12 in. (300 mm)
Wire dimension:	
Fe	0.023–5/64 in. (0.6–2.0 mm)
Ss	0.023–1/16 in. (0.6–1.6 mm)
Al	0.031–1/16 in. (0.8–1.6 mm)
Cored wire	0.035–3/32 in. (0.9–2.4 mm)
Weight	
without U8 ₂ pendant	35.9–40.1 lb. (16.3–18.2 kg)
with U8 ₂ pendant	38.8–44.3 lb. (17.6–20.1 kg)
Maximum weight wire spool	44.1 lb. (20.0 kg)
Dimensions (l×w×h)	
Feeder	23.4×9.8×16.9 in. (595×250×430 mm)
#U8 ₂ pendant	9.8×8.7×2 in. (250×222×50 mm)
Operating temperature	-4 to +131 °F (-20 to +55 °C)
Transport and storage temperature	-40 to +176 °F (-40 to +80 °C)
Shielding gas	All types intended for GMAW welding
Maximum gas pressure	72.5 psi (5 bar, 0.5 Mpa)
Coolant²⁾	ESAB's ready mixed coolant
Maximum coolant pressure	72.5 psi (5 bar, 0.5 Mpa)
Permissible load at +40°C:	
35% duty cycle	630 A
60% duty cycle	500 A
100% duty cycle	400 A
Permissible load at +55 °C:	
35% duty cycle	600 A
60% duty cycle	450 A
100% duty cycle	350 A
Enclosure class³⁾	IP44

¹⁾ For "RobustFeed U8₂, Offshore, Water", "RobustFeed U8₂, Offshore, Water, Push Pull"

²⁾ RobustFeed U8₂ pendant enclosure class is IP23.

Duty cycle

The duty cycle refers to the time as a percentage of a ten-minute period that you can weld or cut at a certain load without overloading.

Enclosure class

The **IP** code indicates the enclosure class, i.e. the degree of protection against penetration by solid objects or water.

Equipment with the **IP44** marking is intended for indoor and outdoor use and can withstand rain from all directions.

Equipment marked **IP23** is intended for indoor and outdoor use.

4 INSTALLATION

The installation must be carried out by a professional.

**WARNING!**

When welding in an environment with increased electrical danger, only power sources intended for this environment may be used. These power sources are marked with the symbol

**CAUTION!**

This product is intended for industrial use. In a domestic environment, this product may cause radio interference. It is the user's responsibility to take adequate precautions.

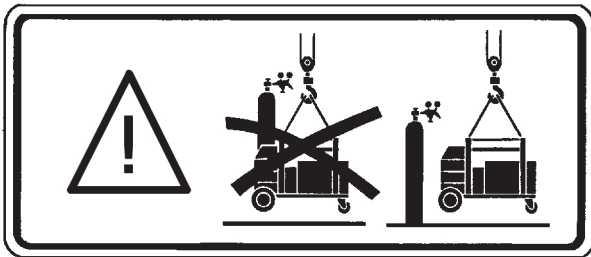

4.1 Lifting instructions

**CAUTION!**

Risk of crushing when lifting the wire feeder. Protect yourself and warn bystanders of the risk.

**CAUTION!**

To avoid personal injury and damage to the equipment, lift using the methods and attachment points detailed below.

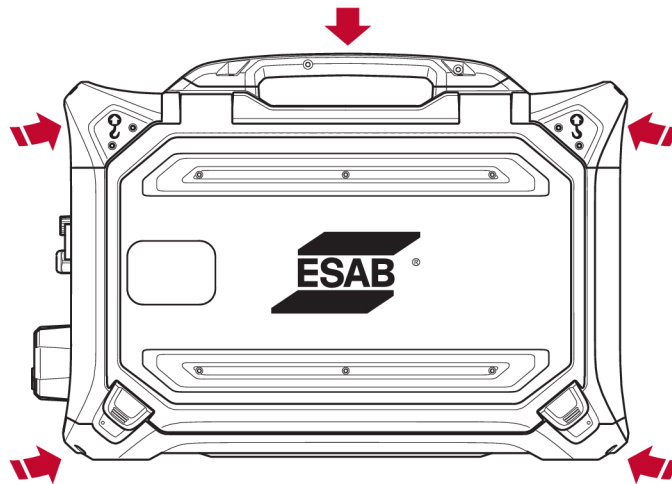

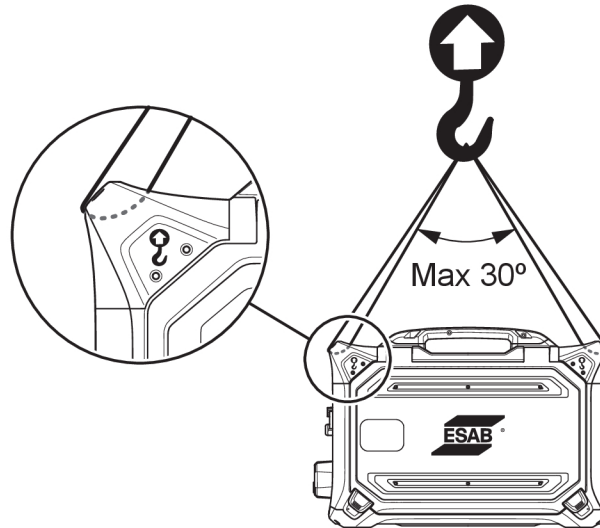

CAUTION!

Do not place heavy objects on the wire feeder when lifting. Objects should not be secured. The lifting points are rated for a **maximum total weight of 44 kg/97 lb** when lifted using the two outer upper lifting handles in accordance with the illustration above.

The 44 kg/97 lb approved weight includes the wire feeder and any accessories (the standard feeder weight is 18.5 kg/40.8 lb). For all weights, please see the TECHNICAL DATA chapter.

5 OPERATION

General safety regulations for handling the equipment can be found in the "SAFETY" chapter of this manual. Read it through before you start using the equipment!



WARNING!

To avoid shock, do not touch the electrode wire or parts in contact with it, or uninsulated cable or connections.



NOTE!

When moving the equipment, use the handle intended for transportation. Never pull the equipment by the welding torch.

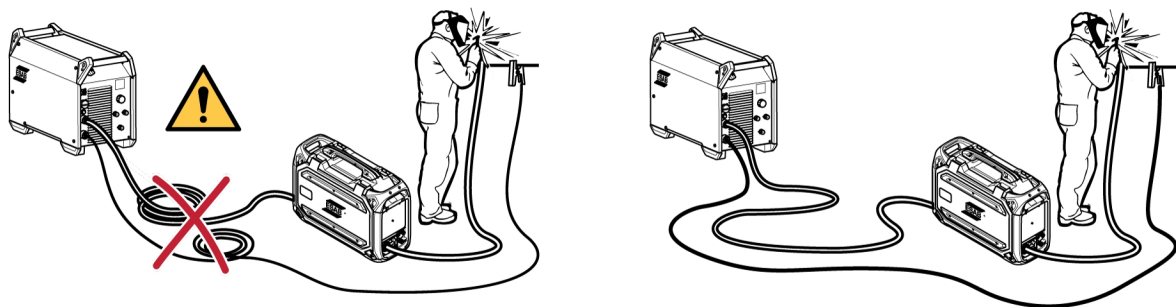

WARNING!

Wire feeders are intended to be used with power sources in GMAW and SMAW mode. If used in GMAW, the SMAW holder must be disconnected from the wire feeder and the OKC must be covered. If used in SMAW, the GMAW torch must be isolated or kept in the torch holder if available, or else the torch/holder becomes live or energized.

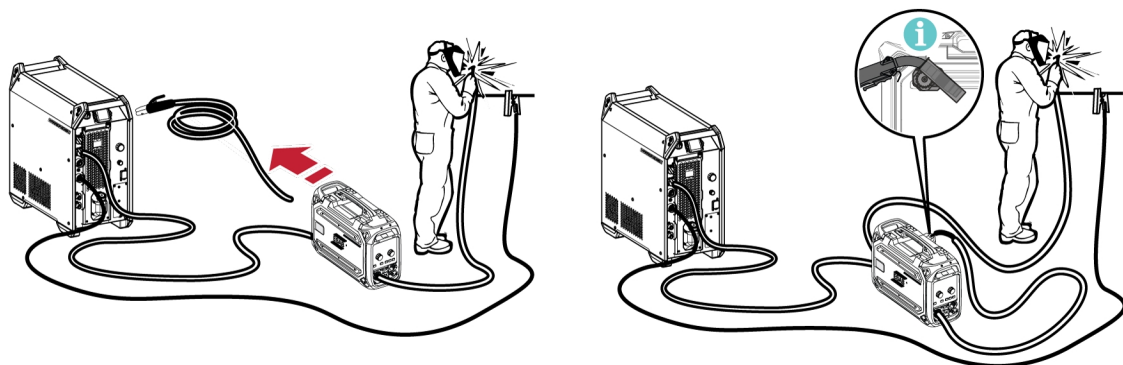

WARNING!

Make sure the side panels are closed during operation.



WARNING!

To prevent the reel from sliding off the hub, lock the reel in place by tightening the nut.

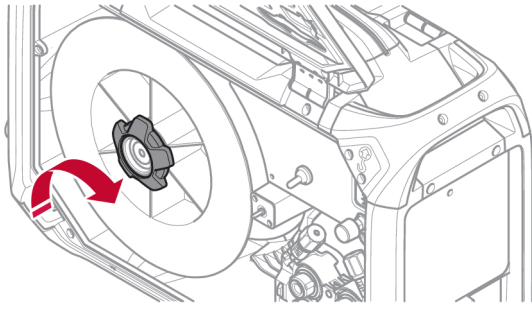
**CAUTION!**

Before threading welding wire, make sure the chisel point and burrs have been removed from the end of the wire to prevent the wire from jamming in the torch liner.

**WARNING!**

Rotating parts can cause injury, take great care.

**WARNING!**

Secure the equipment, especially if used on an uneven or sloping surface.

5.1 Recommended maximum current values for connection

At an ambient temperature of +25 °C and a normal 10-minute cycle:

Cable area	Duty cycle			Voltage loss per 10 m
	100%	60%	35%	
70 mm ²	350 A	400 A	480 A	0.28 V / 100 A
95 mm ²	400 A	500 A	600 A	0.21 V / 100 A

At an ambient temperature of +40 °C and a normal 10-minute cycle:

Cable area	Duty cycle			Voltage loss per 10 m
	100%	60%	35%	
70 mm ²	310 A	350 A	420 A	0.30 V / 100 A
95 mm ²	375 A	430 A	525 A	0.23 V / 100 A

Duty cycle

The duty cycle refers to the time as a percentage of a ten-minute period that you can weld or cut at a certain load without overloading.

5.2 Connections and control devices

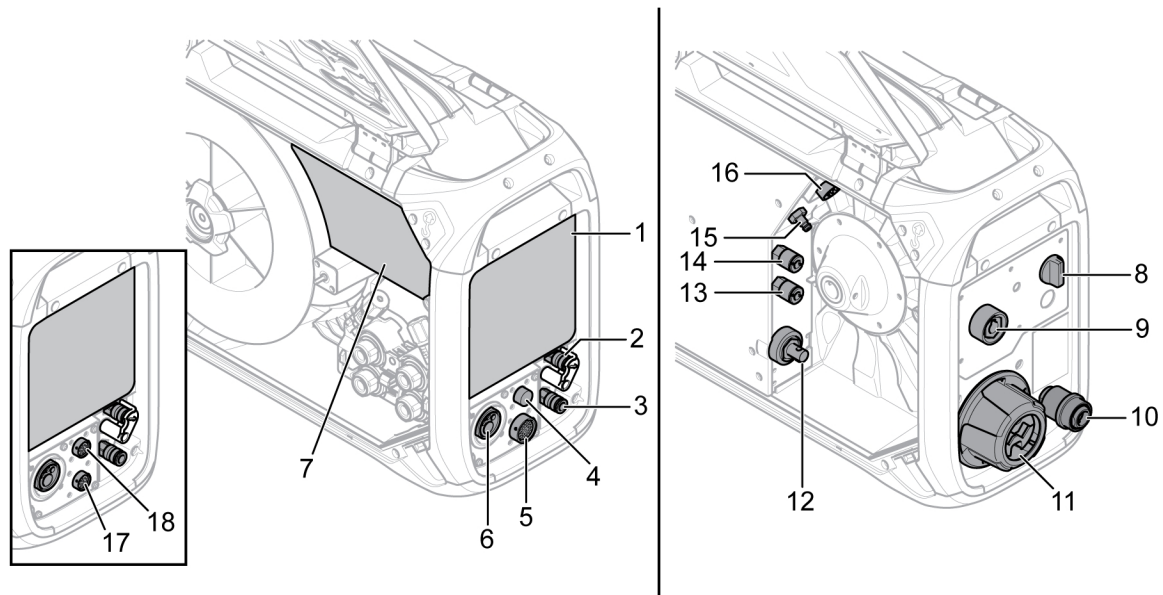

- | | |
|---|--|
| 1. External blank panel. See the "CONTROL PANEL" chapter. | 10. Wire inlet for use with Marathon Pac™ (optional) |
| 2. Connection for cooling liquid to the welding torch, with ELP ¹⁾ (only on product variants with ELP) | 11. Interconnection strain relief for cables from power source |
| 3. Connection for cooling liquid from the welding torch | 12. Connection for welding current from power source (OKC) |
| 4. Connection for Tweco trigger cable (only in combination with Tweco torch) | 13. Connection for cooling liquid to the power source (the cooling unit) |
| 5. Connection from U8 ₂ pendant | 14. Connection for cooling liquid from the power source (the cooling unit) |
| 6. Connection for GMAW welding torch (Euro or Tweco type) | 15. Connection for shielding gas |
| 7. Internal control panel (see the "CONTROL PANEL" chapter) | 16. Connection for control cable from power source |
| 8. Heat kit switch (Offshore versions) | 17. Connection for push-pull torch unit (Tweco variant) |
| 9. Connection for SMAW welding torch (OKC) ³⁾ (only on product variants with SMAW) | 18. Connection for U8 ₂ pendant (Tweco variant) |

¹⁾ ELP = ESAB Logic Pump (see the "Cooling liquid connection" section)



WARNING!

The right and left side doors of the wire feed unit must be closed during welding and/or wire feeding. Never weld or feed the wire unless both doors are closed.

²⁾ Electrical hazard! During **GMAW welding**, the **SMAW electrode** should be removed from the electrode holder and must be kept away from the work piece and any other current leading material. If possible, the electrode holder should be removed from the welding unit OKC connector and the connector should be covered with an isolating cap.

³⁾ Electrical hazard! During **SMAW welding**, the wire stick out should be cut to minimize the possibility of unintentional contact with the **GMAW torch**. The torch must be kept away from the work piece and any other current leading material!



CAUTION!

Connect Tweco Push-Pull torch to connection 17 only. **DO NOT** connect to connection 18.

5.3 Cooling liquid connection

When connecting a liquid cooled welding torch, the main power supply switch of the power source must be in the OFF position and the cooling unit switch must be in position 0.

Some wire feed unit variants with cooling liquid connections included are equipped with a detection system called ESAB Logic Pump (ELP), which checks that the water hoses are connected. When connecting a water-cooled welding torch, the water pump starts automatically. The detection only works with power sources that are equipped with ELP (for instance Aristo 4004i together with Cool 1). For power sources **without** ELP function (for instance Aristo 500ix together with Cool 2), the cooler unit must be turned on and off **manually**.



CAUTION!

Non-ELP feeder variants should **not** be used together with power sources equipped with ELP! If non-ELP feeders are used together with power sources equipped with ELP, the liquid cooled torch may be damaged due to lack of coolant flow!

A liquid cooling kit can be ordered as an accessory (see the "ACCESSORIES" appendix).

5.4 Retrofitting an interconnection strain relief kit

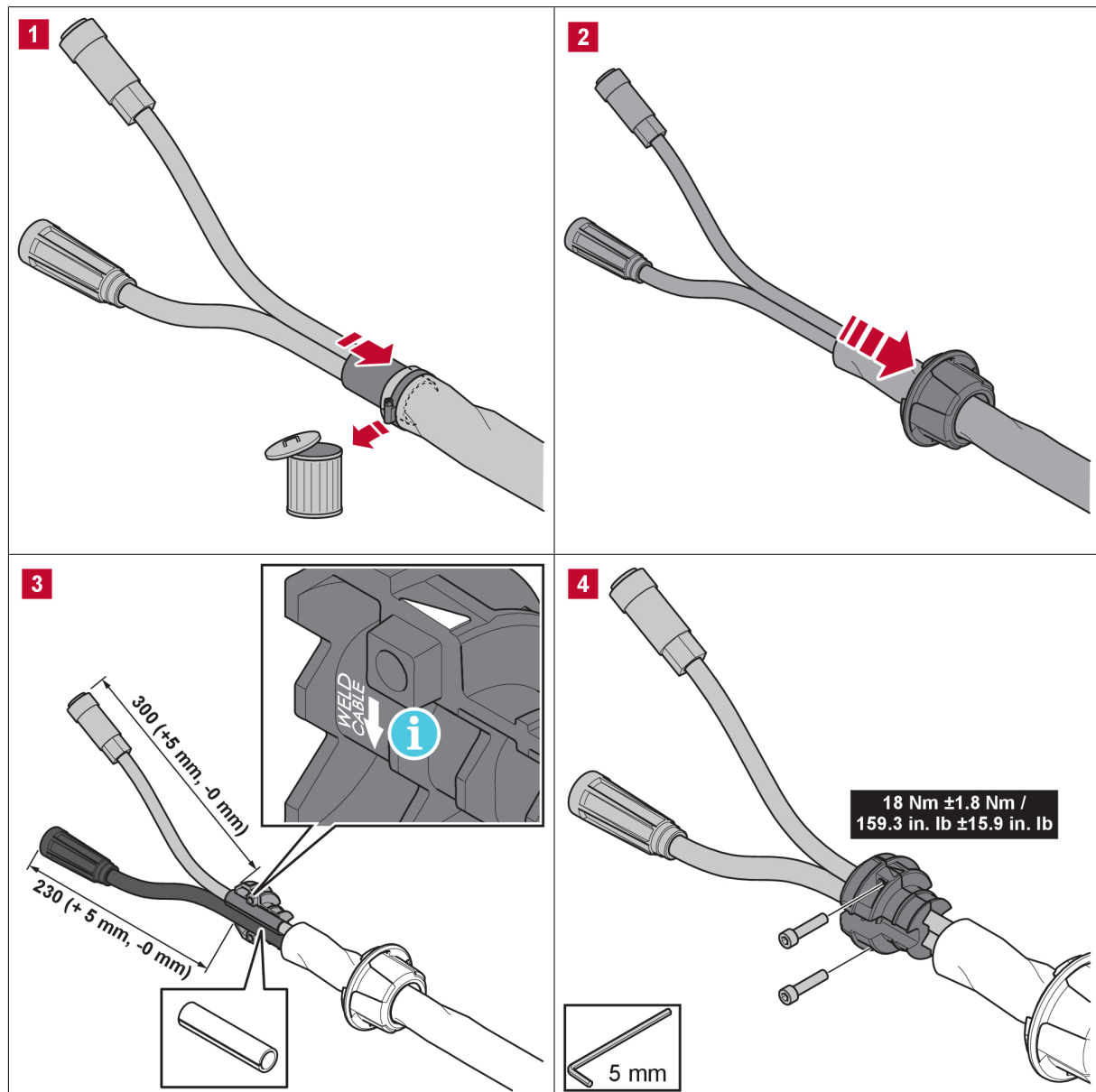

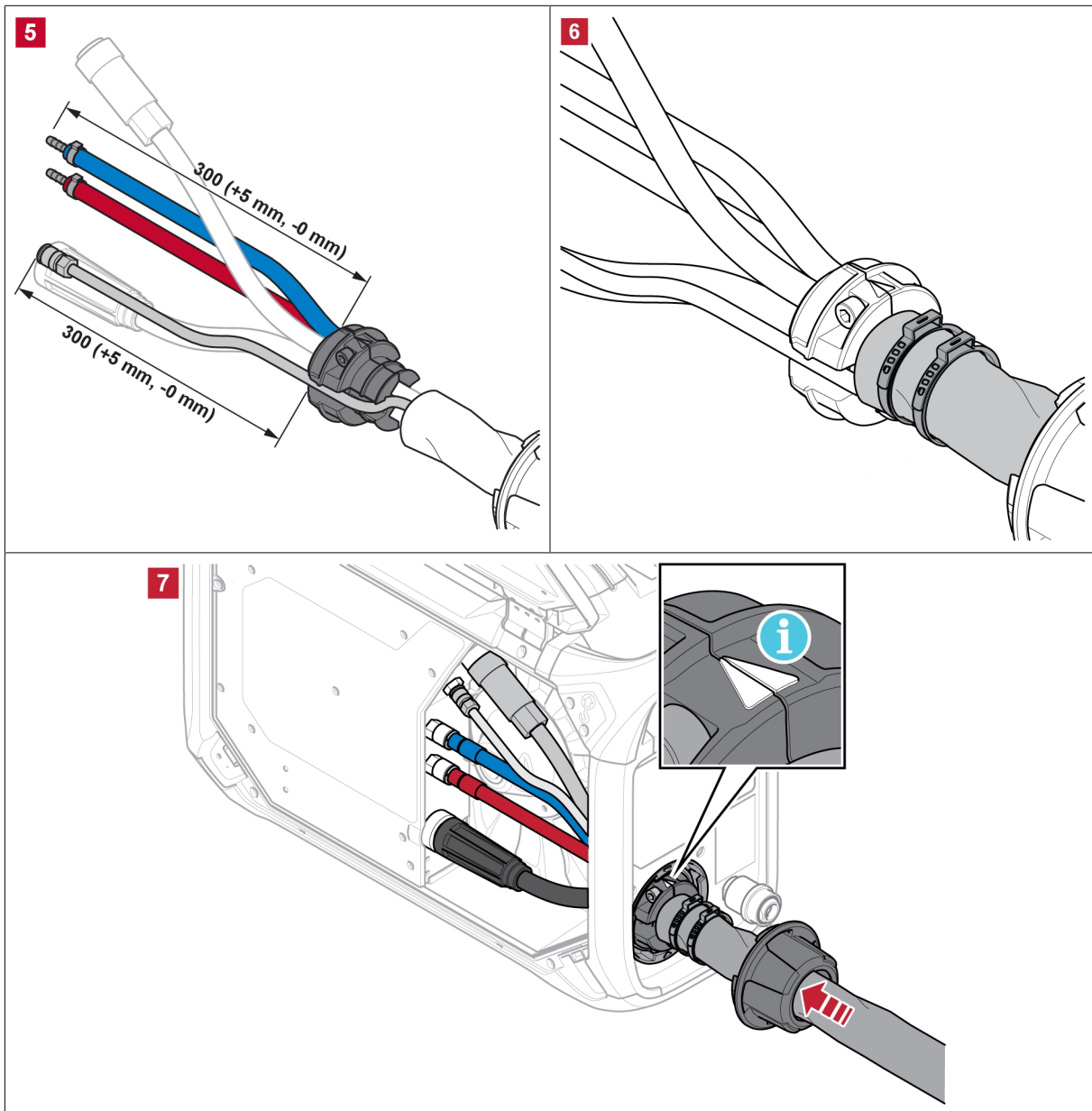

The diagram above illustrates the retrofitting of the interconnection strain relief kit (order no. 0446 050 881) where the welding current and control cables, in addition to the cooling liquid and shielding gas hoses (if applicable) are routed through the strain relief device.

Using a pre-assembled interconnection cable kit, which includes the strain relief, is also an option (see the "ACCESSORIES" appendix).

**NOTE!**

- The interconnection strain relief should be clamped onto clean cables.
- Locate the welding current cable in the larger of the two holes in the strain relief clamp!
- Ensure that the cable ties around the insulating sleeve are tightened properly!

5.5 Heat kit switch (Offshore versions only)

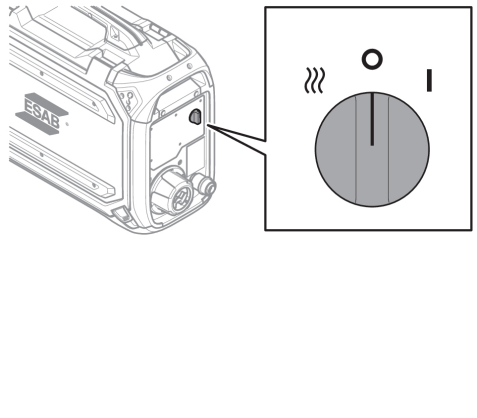
○	Welding OFF ¹⁾	
	Welding ON	
≡	Heat ON and welding OFF The bobbin area is heated to keep the welding wire dry. Heating the bobbin area is highly advantageous in environments with high levels of humidity or where the temperature fluctuates throughout the day. ¹⁾	

¹⁾The external control panel will be in OFF condition, when any of these settings are selected.

5.6 Starting procedure

When the wire feed starts, the power source generates the welding voltage. If there is no welding current flow within three seconds, the power source switches the welding voltage off.

The wire feed continues until the welding torch's switch is switched to off.



NOTE!

It is important that the power source used together with the feeder is set to GMA (MIG/MAG) mode when the system is powered on! This is to ensure that calibration is made between the feeder and the power source before any welding can be done. If the power source is set to another welding method at power on, the voltage settings on the feeder panel **cannot** be guaranteed! If this happens, switch off the power source, set the mode switch to GMA (MIG/MAG) and restart the power source again!

5.7 Lighting inside the wire feed unit

Lights are fitted inside the cabinet of the wire feed unit.

The light located by the wire bobbin turns on automatically when welding starts or when the left side door is opened. The light is automatically turned off 4 minutes after welding has stopped or the side door has been closed.

The light located by the feeder mechanism turns on automatically when the left side door is opened and turns off when the door is closed again.

The lights automatically switch on when the feeder is started, when any of the parameters on the internal control panel are changed, when wire inching is performed and after welding tasks. The lights automatically switch off after a few minutes.

5.8 Bobbin brake

The bobbin brake force should be increased just enough to prevent wire feed overrun. The actual brake force required depends on the wire feed speed and the size and weight of the bobbin spool.

Do not overload the bobbin brake. If the brake force is too high, it may overload the motor, resulting in a lower-quality welding result.

The bobbin brake force is adjusted using the 6-mm hexagon Allen screw in the middle of the spool nut.

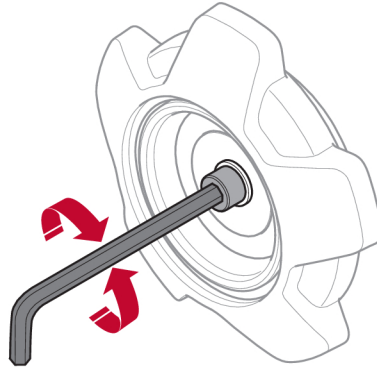

5.9 Changing and loading wire

- 1) Open the left door of the wire feeder.
- 2) Untighten and remove the brake hub nut and remove the old wire spool.
- 3) Insert a new wire spool into the feeder unit and straighten out the new welding wire by 10–20 cm. File away any burrs and sharp edges from the end of the wire before inserting it into the feeder mechanism.
- 4) Lock the wire spool onto the brake hub by tightening the brake hub nut.
- 5) Thread the wire through the feeder mechanism (according to the illustration on the inside of the feeder unit).
- 6) Close and lock the left door of the wire feeder

5.10 Changing feed rollers

When changing to a different type of wire, the feed rollers should also be changed to match the new type of wire. For more information about correct feed rollers depending on wire diameter and type, see the WEAR PARTS appendix. For tips about easy access to essential wear parts, see the "Wear parts storage compartment" section in this manual.

- 1) Open the left door of the wire feeder.
- 2) Unlock the feed rollers to be exchanged, by rotating the roller quick lock (A) for each roller.

- 3) Relieve the pressure on the feed rollers, by folding the tensioner units (B) down and thereby releasing the swing arms (C).

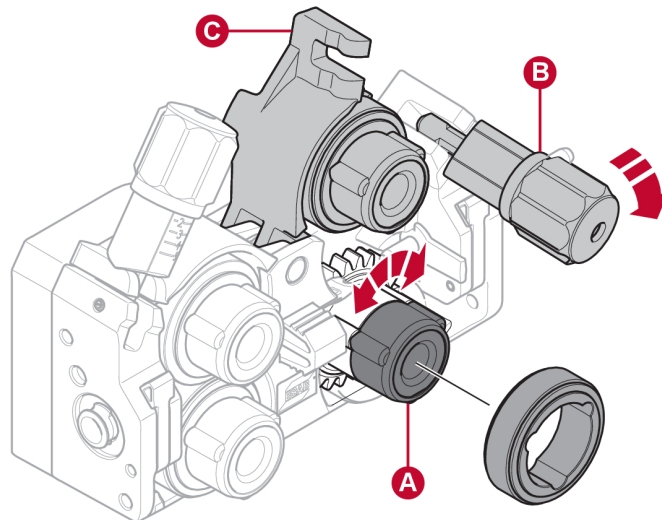

- 4) Remove the feed rollers and install the correct ones (according to the WEAR PARTS appendix).
- 5) Reapply the pressure on the feed rollers, by pushing the swing arms (C) down and secure them using the tensioner units (B).
- 6) Lock the rollers by rotating the roller quick locks (A).
- 7) Close and lock the left door of the wire feeder.

5.11 Changing the wire guides

When changing to a different type of wire, the wire guides may need to be changed to match the new type of wire. For information about the correct wire guides depending on wire diameter and type, see the WEAR PARTS appendix. For tips about easy access to essential wear parts, see the "Wear parts storage compartment" section in this manual.

5.11.1 Inlet wire guide

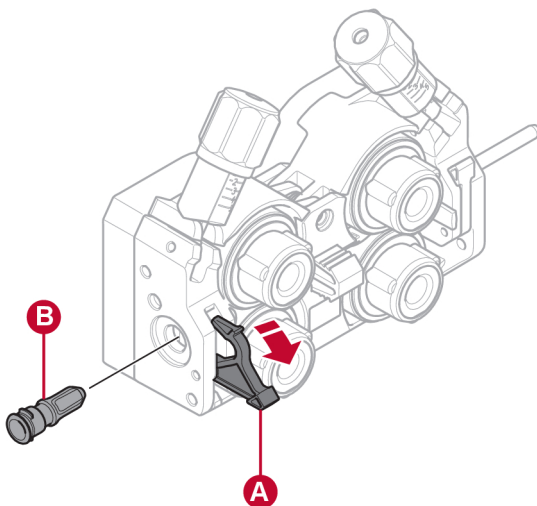

- 1) Unlock the inlet wire guide quick lock (A) by folding it out.
- 2) Remove the inlet wire guide (B).
- 3) Fit the correct inlet wire guide (according to the WEAR PARTS appendix).
- 4) Lock the new inlet wire guide into place using the wire guide quick lock (A).

5.11.2 Middle wire guide

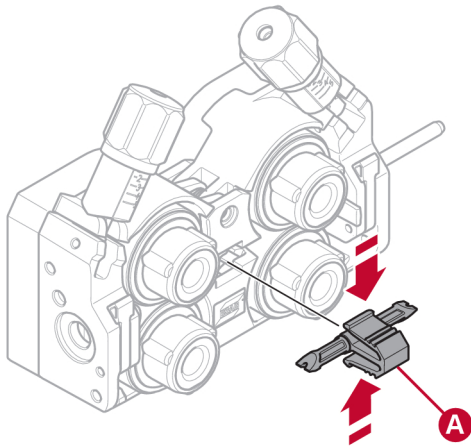

- 1) Apply a small amount of pressure to the middle wire guide clip and remove the middle wire guide (A).
- 2) Push in the correct type of wire guide (according to the WEAR PARTS appendix). The clip automatically locks the wire guide when in the correct position.

5.11.3 Outlet wire guide

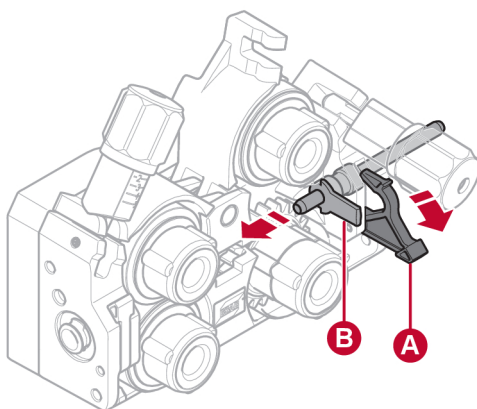

- 1) Remove the lower right feed roller (see the "Changing feed rollers" section).
- 2) Remove the middle wire guide (see the "Middle wire guide" section).
- 3) Unlock the outlet wire guide quick lock (A) by folding it out.
- 4) Remove the outlet wire guide (B).
- 5) Install the correct outlet wire guide (according to the WEAR PARTS appendix).
- 6) Lock the new outlet wire guide into place using the wire guide quick lock (A).
- 7) Reattach the second pair of feed rollers and reapply the roller pressure (see the "Changing feed rollers" section).

5.12 Roller pressure

The roller pressure should be adjusted separately on each tensioner unit, depending on the material and diameter of the wire used.

Start by making sure that the wire moves smoothly through the wire guide. Then set the pressure of the wire feeder's pressure rollers. It is important that the pressure is not too high.

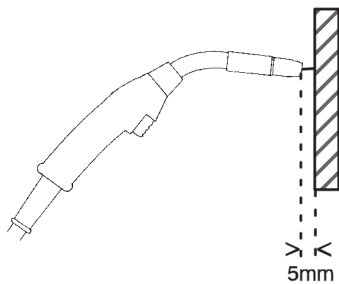

Figure A

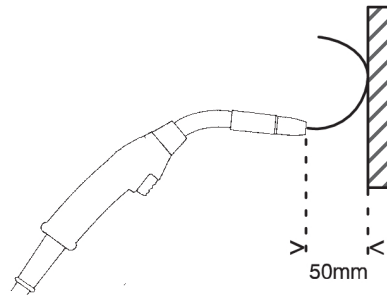

Figure B

To check that the feed pressure is set correctly, you can feed out the wire against an insulated object, e.g. a piece of wood.

When you hold the welding torch approx. (5 mm) from the piece of wood (figure A) the feed rollers should slip.

If you hold the welding torch approx. (50 mm) from the piece of wood, the wire should feed out and bend (figure B).

5 OPERATION

The table below serves as a guideline showing approximate roller pressure settings for standard conditions with correct bobbin brake force. If the torch cables are long, dirty or worn, the pressure setting may need to be increased. Always check the roller pressure setting on a case-by-case basis by feeding out the wire against an insulated object as described above. A table showing approximate settings can also be found on the inside of the left door of the wire feeder.

		Wire diameter (in.) (mm)	.023	.030	.040	.045	.052	1/16	.070	5/64	3/32	
			0.6	0.8	1.0	1.2	1.4	1.6	1.8	2.0	2.4	
		Pressure setting										
Wire material	Fe, Ss	Tensioner unit 1	2.5									
		Tensioner unit 2	3–3.5									
	Cored	Tensioner unit 1			2							
		Tensioner unit 2			2.5–3							
	Al	Tensioner unit 1		1–1.5								
		Tensioner unit 2		2–3								

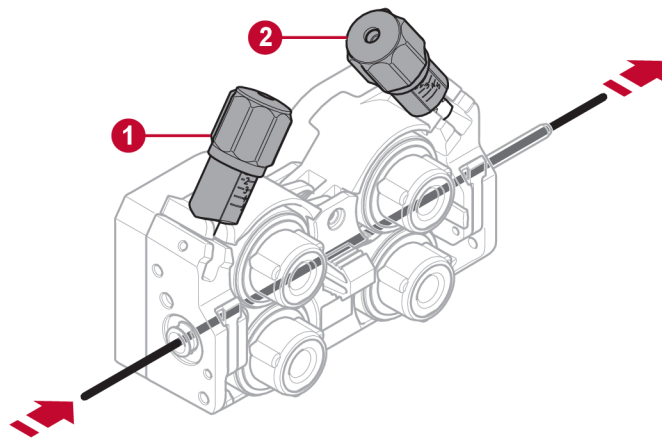

1. Tensioner unit 1

2. Tensioner unit 2

5.13 Wear parts storage compartment

A wear parts storage compartment is located on the inside of the left door of the wire feeder, providing easy access to an extra set of rollers and wire guides.

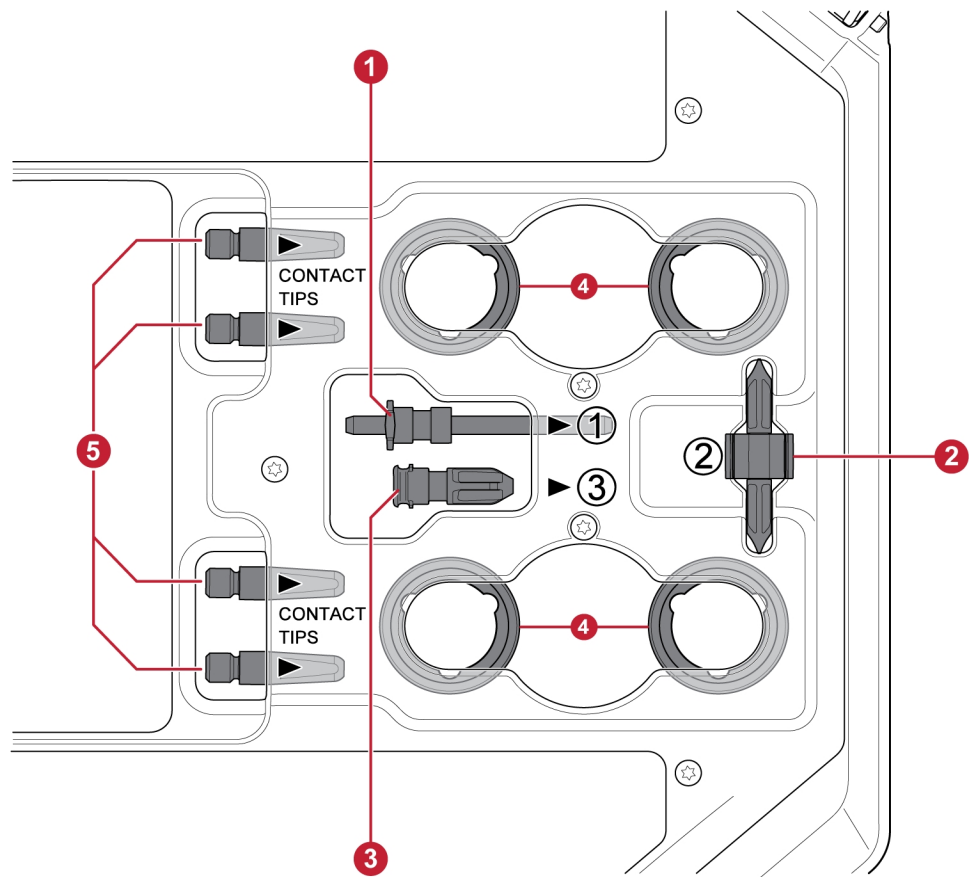

- | | |
|----------------------|---|
| 1. Inlet wire guide | 4. Feed rollers (×4 pcs.) |
| 2. Middle wire guide | 5. Contact tips for the welding torch (×4 pcs.) |
| 3. Outlet wire guide | |

5.14 Attachment of the wheel kit

5.14.1 Attaching the wheels to the wheel kit frame

Before attaching the wire feed unit to the wheel kit, fasten the wheels to the frame using the M12 screws, washers and nuts, using a tightening torque of 40 ± 4 Nm (354 ± 35.4 in. lb). The fixed wheels at the rear end should be positioned parallel to the frame.

5.14.2 Wire feed unit in vertical position

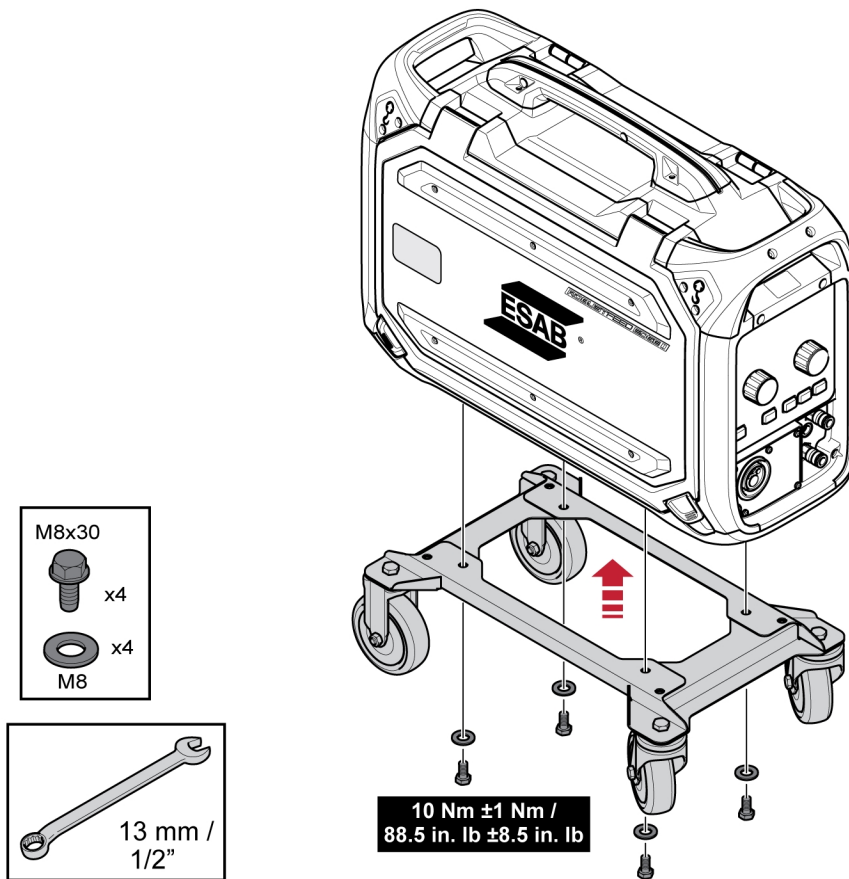

5.14.3 Wire feed unit in horizontal position

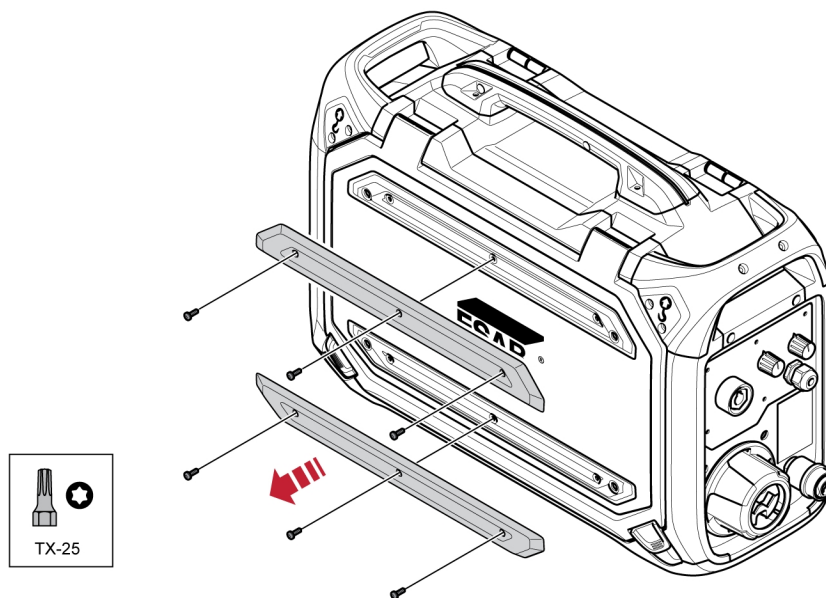

NOTE!

In order to attach the wire feeder to the wheel kit in the horizontal position, the two bumpers on the wire feeder door must be removed.

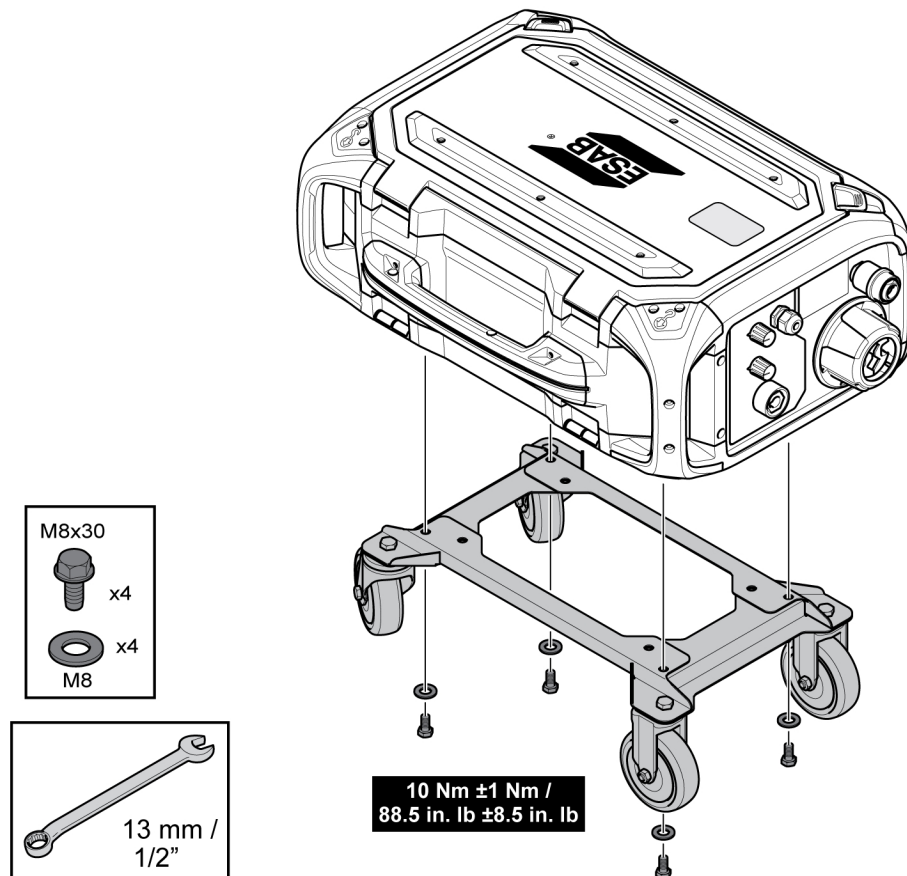

5.15 Attaching both the wheel kit and the torch strain relief accessory

- 1) If the torch strain relief accessory is to be used with the wheel kit when it is fitted in the vertical position, the assembly steps below must be completed in the following order:

Attach the torch strain relief to the wire feed unit, using the two Torx 5 screws.

Attach the wheel kit to the wire feeder using the two screw joints near the rear end of the wire feeder. Ensure that the two distance washers are inserted between the wheel kit and the wire feeder.

Fasten the wheel kit **and** the torch strain relief to the wire feeder using the two screw joints located closer to the front end of the wire feeder.

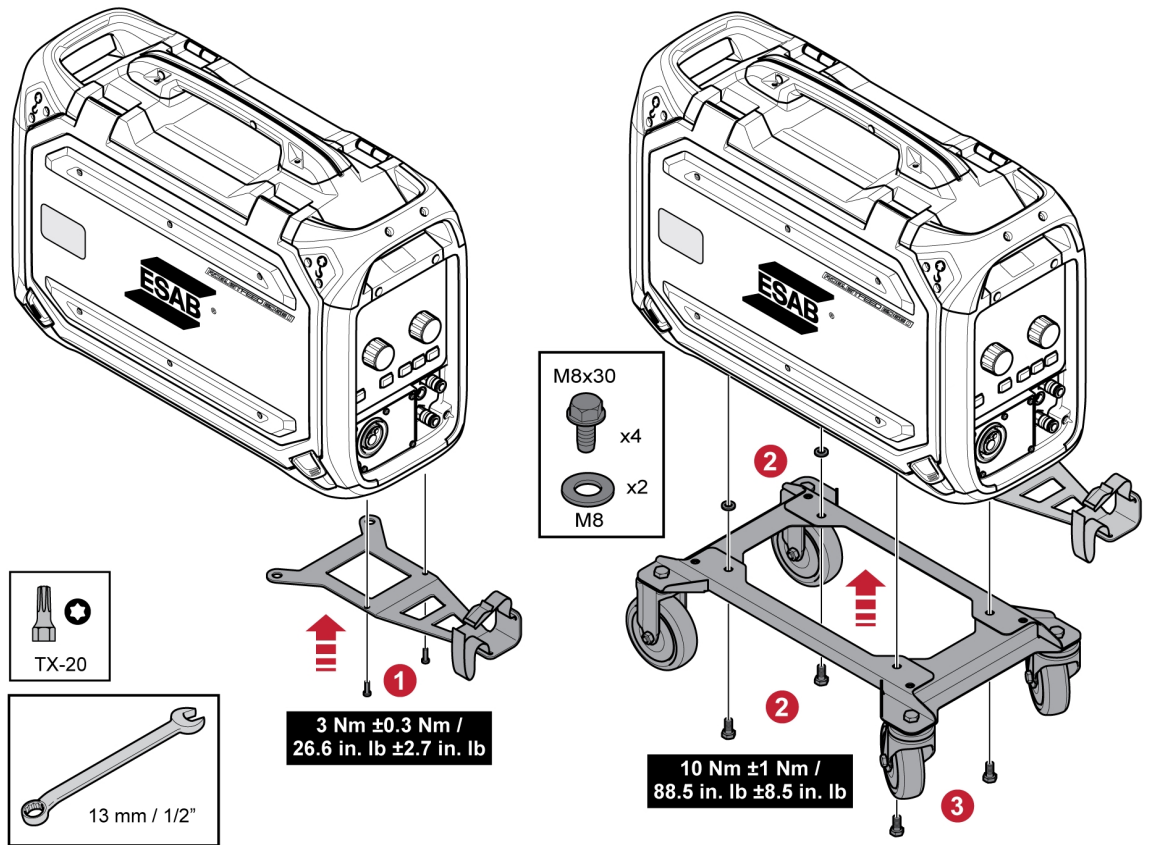

5.16 Marathon Pac™ installation

1

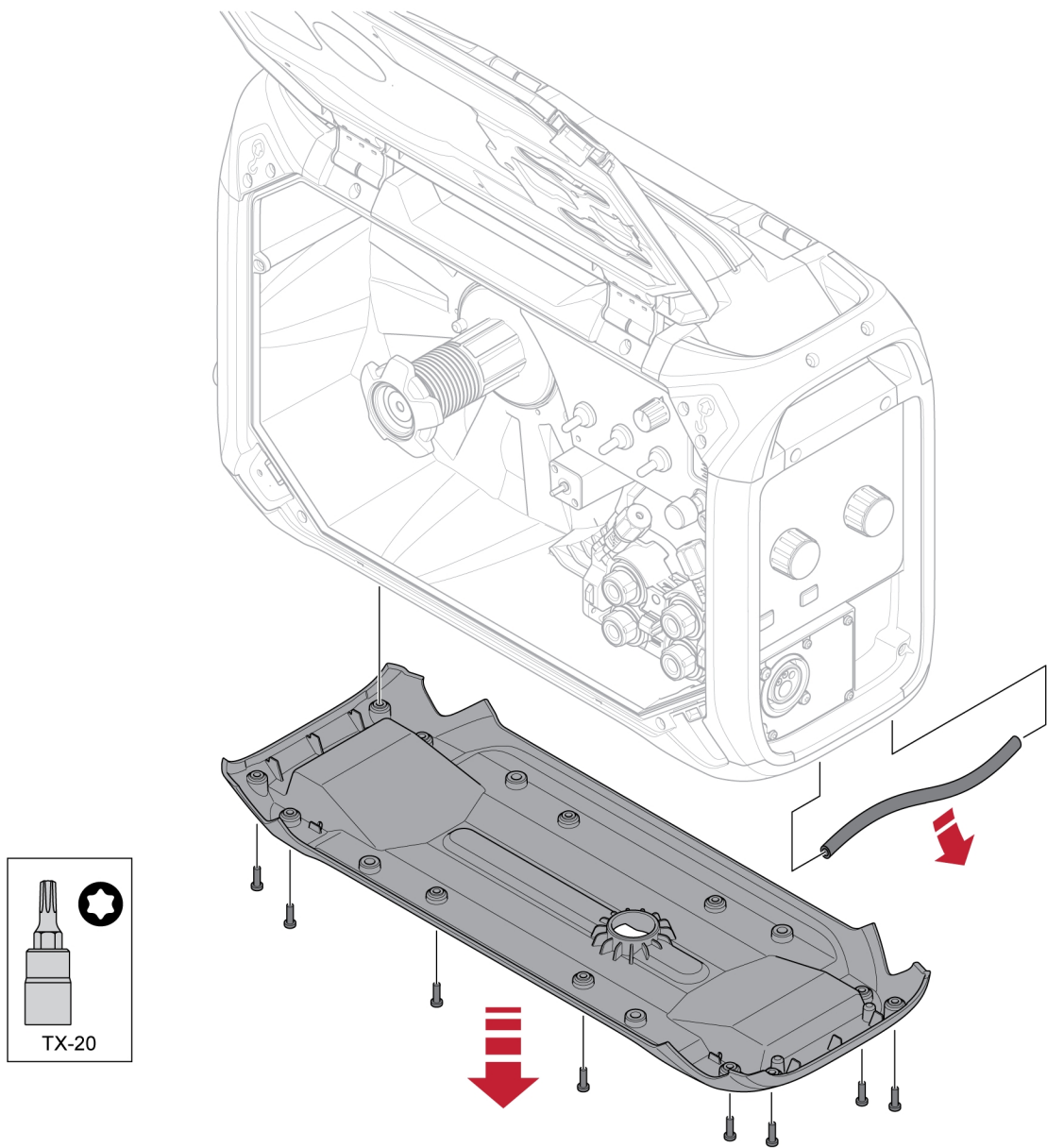

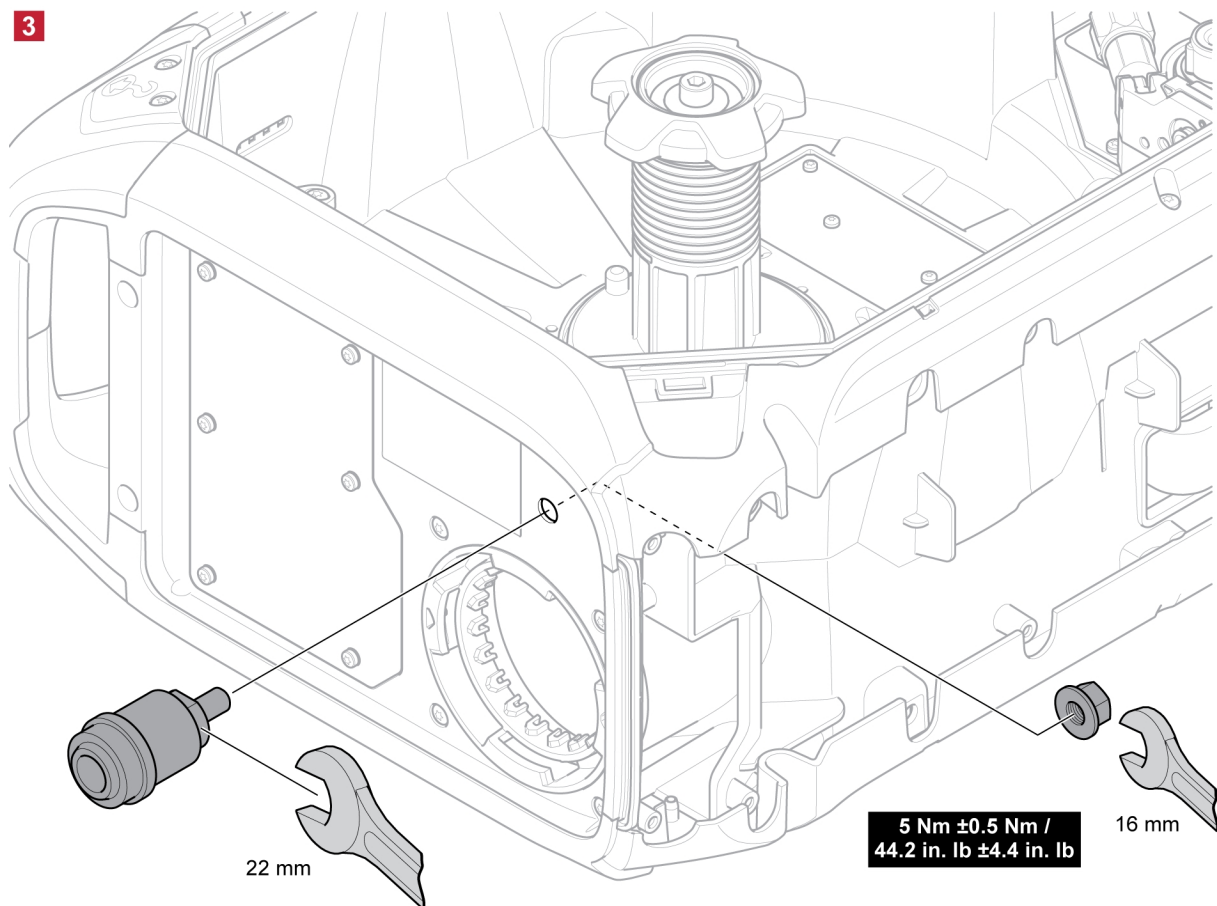
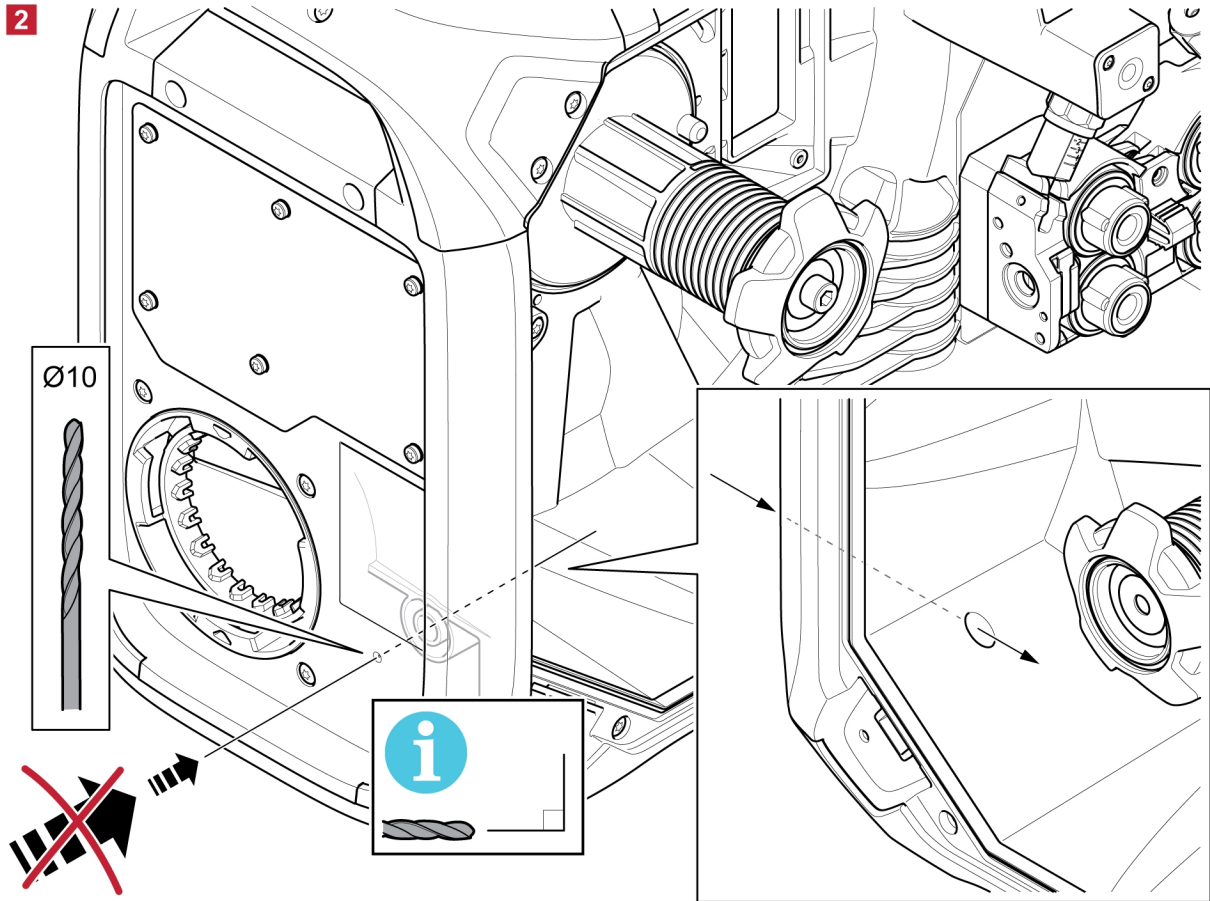

4

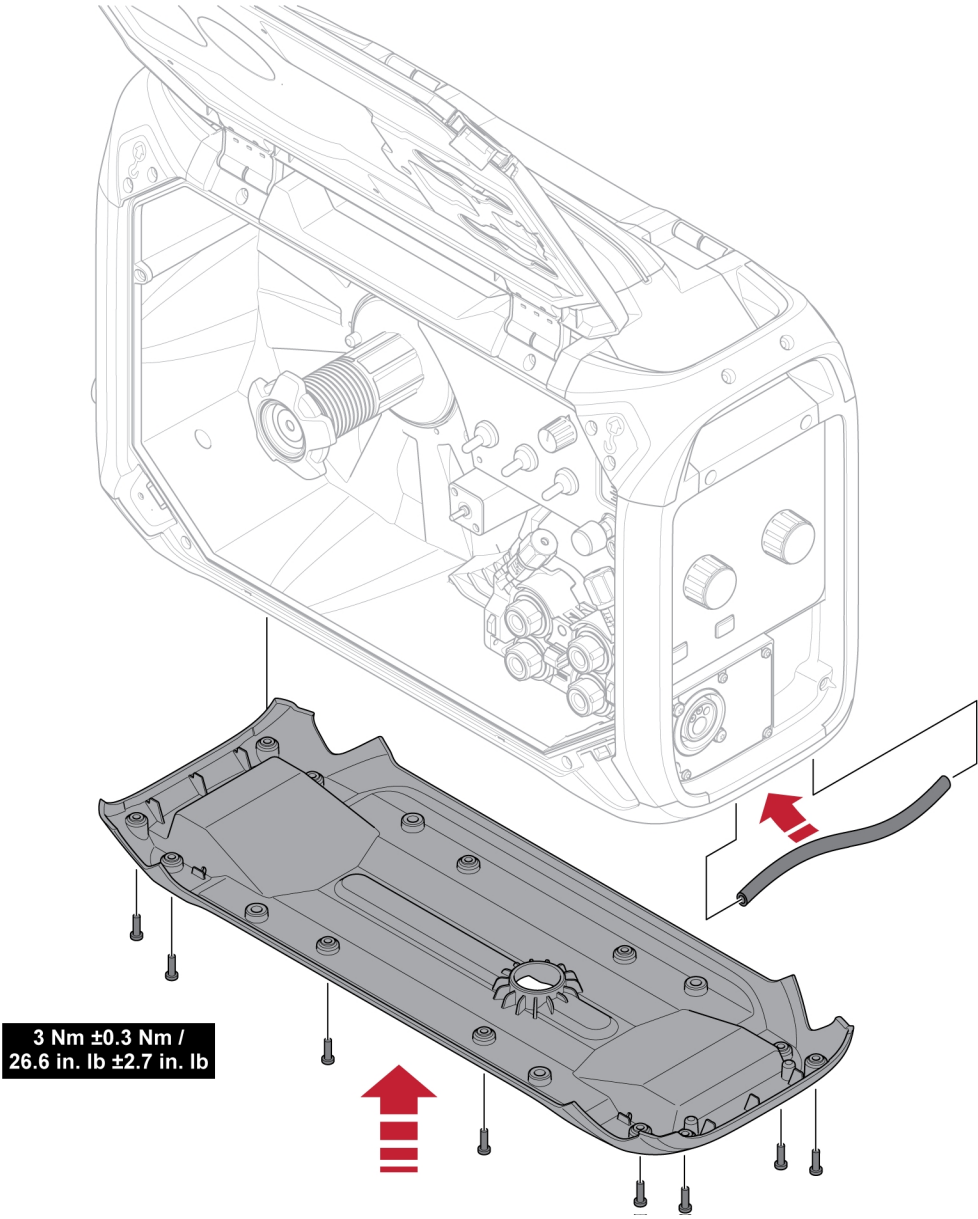

6 CONTROL PANEL

6.1 External blank panel

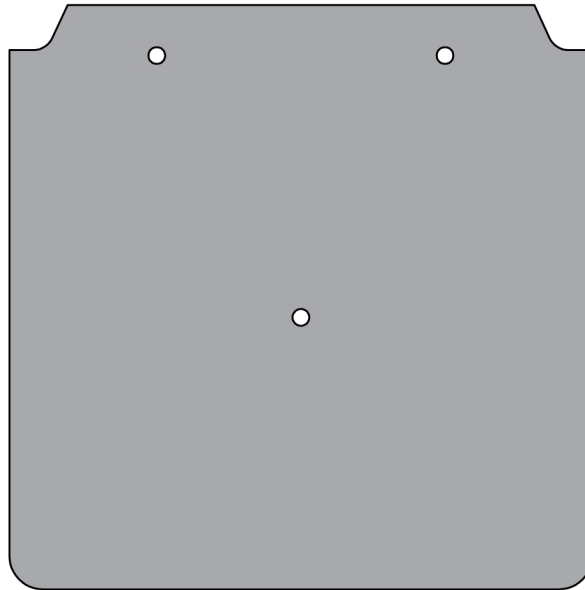

NOTE!

The feeder with an external blank panel can be used with U8₂ control panel.

For installation of U8₂ on RobustFeed U8₂, see the "ASSEMBLY INSTRUCTIONS" chapter of this manual.

6.2 Internal control panel



1. Knob for setting the gas flow rate (only for product variants containing a gas flow meter)

6.3 Setting the gas flow

<p>The close-up shows the 'Ar/CO₂' scale with markings for 30, 25, 20, 15, 10, and 5 L/min, and corresponding markings for 60, 48, 36, 24, and 12 CFH. Below the scale is a grey knob.</p>	<p>The gas flow is adjusted using the knob on the internal control panel. The present gas flow rate is given on the gas flow meter above the knob.</p> <p>NOTE! The reading on the flow meter scale will only be correct if the wire feeder is in upright position.</p>
---	---

6.4 Rotating the external control panel

To use the wire feeder in the horizontal position, the external control panel may be rotated 90°.

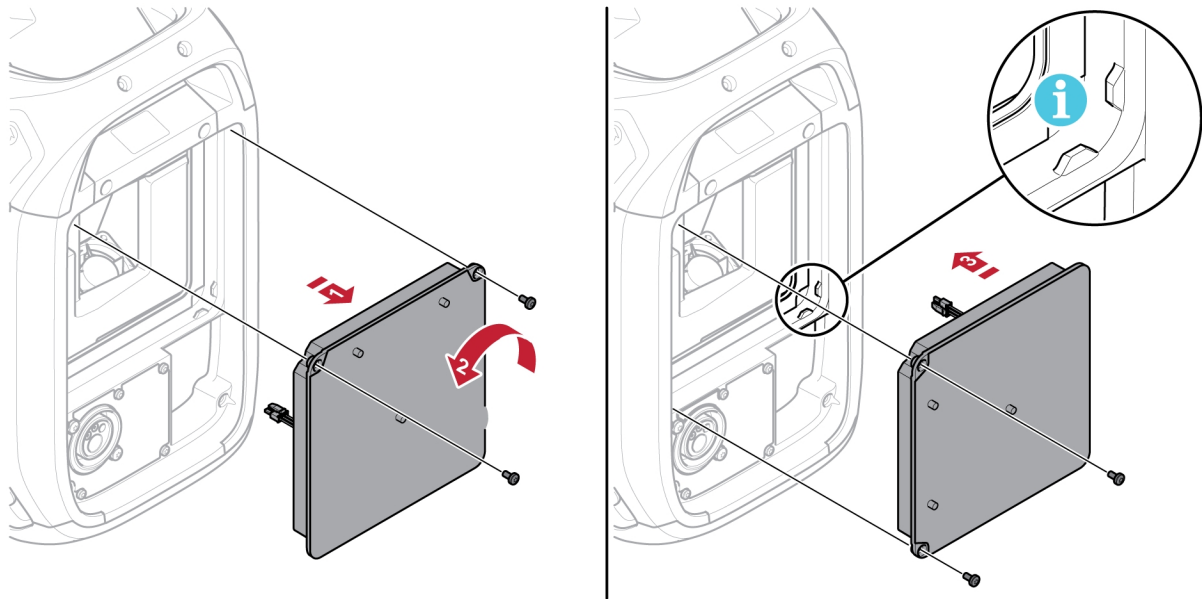

- 1) Remove the two screws for the control panel and remove the panel.
- 2) Rotate the control panel 90° counter-clockwise.
- 3) Attach the control panel, ensuring that the small tabs are in the correct position.
- 4) Fasten the screws.

7 MAINTENANCE

**NOTE!**

Regular maintenance is important for safe and reliable operation.

**CAUTION!**

All warranty undertakings from the supplier cease to apply if the customer attempts any work to rectify any faults in the product during the warranty period.

7.1 Inspection, cleaning and replacement

Wire feed mechanism

Regularly check that the wire feed unit is not clogged with dirt.

- Cleaning and replacement of worn parts in the mechanism of the wire feed should take place at regular intervals in order to achieve trouble-free wire feeding. Note that if pretensioning is set too hard, this can result in abnormal wear on the pressure roller, feed roller, and wire guide.
- Cleaning of the liners and other mechanical parts of the wire feed mechanism should be carried out at regular intervals or if the wire feed seems slow. Use compressed air for this task.
- Changing nozzles
- Checking the driving wheel
- Changing the cog-wheel package

Bobbin holder

- Inspect at regular intervals that the brake hub sleeve and the brake hub nut are not worn out and that they lock properly. Replace if necessary.

Welding torch

- The wear parts of the welding torch should be cleaned and replaced at regular intervals in order to achieve trouble-free wire feed. Regularly blow the wire guide clean and clean the contact tip.

8 TROUBLESHOOTING

For explanation of errors that may appear on the external control panel, see the instruction manual for the control panel in question.

Perform the following checks and inspections before sending for an authorized service technician.

Fault symptom	Corrective actions
The wire feed is slow/stiff when moving through the wire feed mechanism.	<ul style="list-style-type: none">• Clean the liners and other mechanical parts of the wire feed mechanism using pressurized air.• Check and adjust the roller pressure as per the table on the decal on the left side door.

9 ORDERING SPARE PARTS



CAUTION!

Repair and electrical work should be performed by an authorized ESAB service technician.
Use only ESAB original spare and wear parts.

RobustFeed U8₂ is designed and tested in accordance with the international and European standards **EN IEC 60974-5** and **EN IEC 60974-10 Class A**, Canadian standard **CAN/CSA-E60974-5** and US standard **ANSI/IEC 60974-5**. It is the obligation of the service unit which has carried out the service or repair work to make sure that the product still conforms to the mentioned standards.

Spare parts and wear parts can be ordered through your nearest ESAB dealer, see the back cover of this document. When ordering, please state product type, serial number, designation and spare part number in accordance with the spare parts list. This facilitates dispatch and ensures correct delivery.

10 ASSEMBLY INSTRUCTIONS

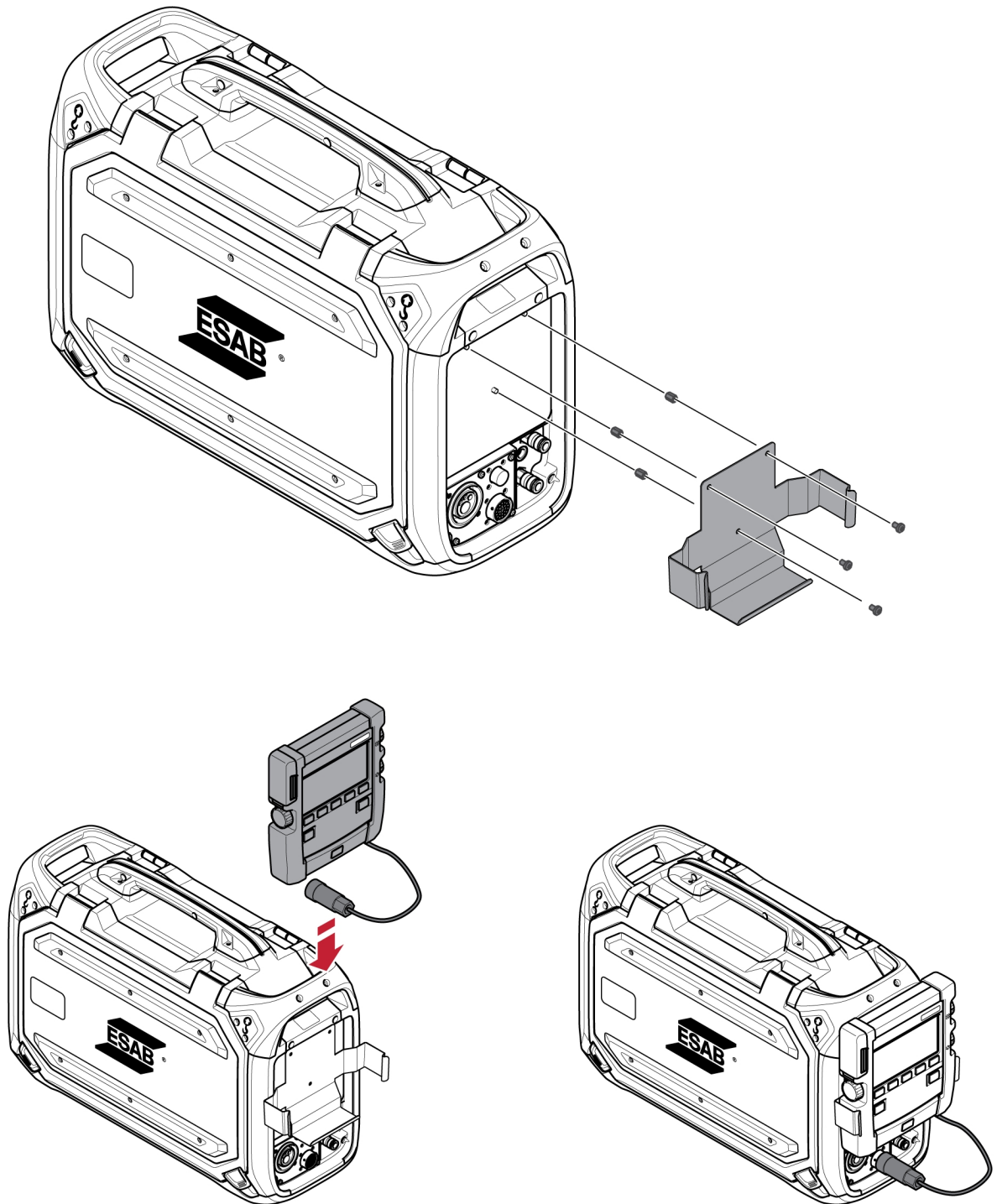

APPENDIX

WIRING DIAGRAM

RobustFeed U8₂

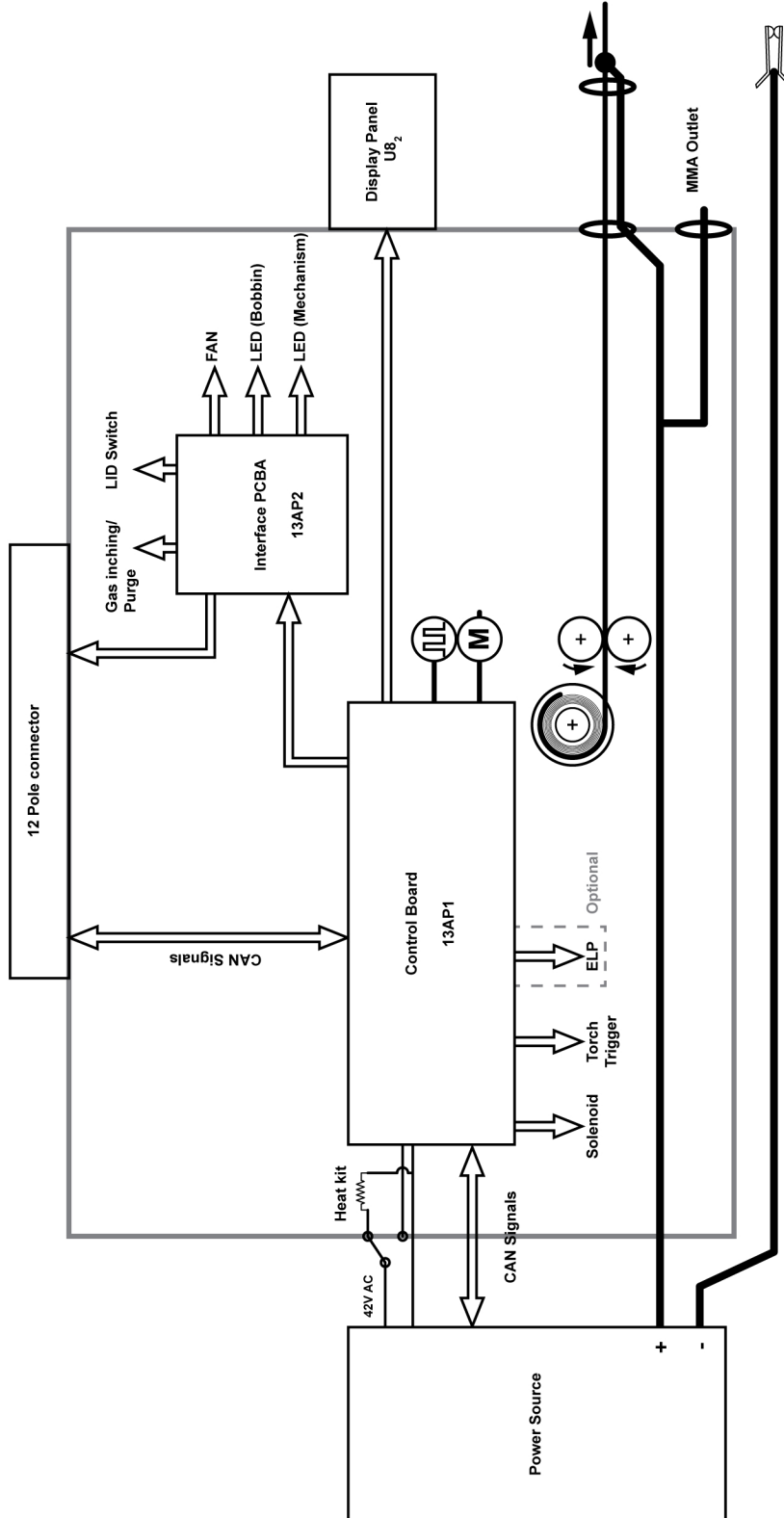

RobustFeed U₈ Tweco Push-Pull

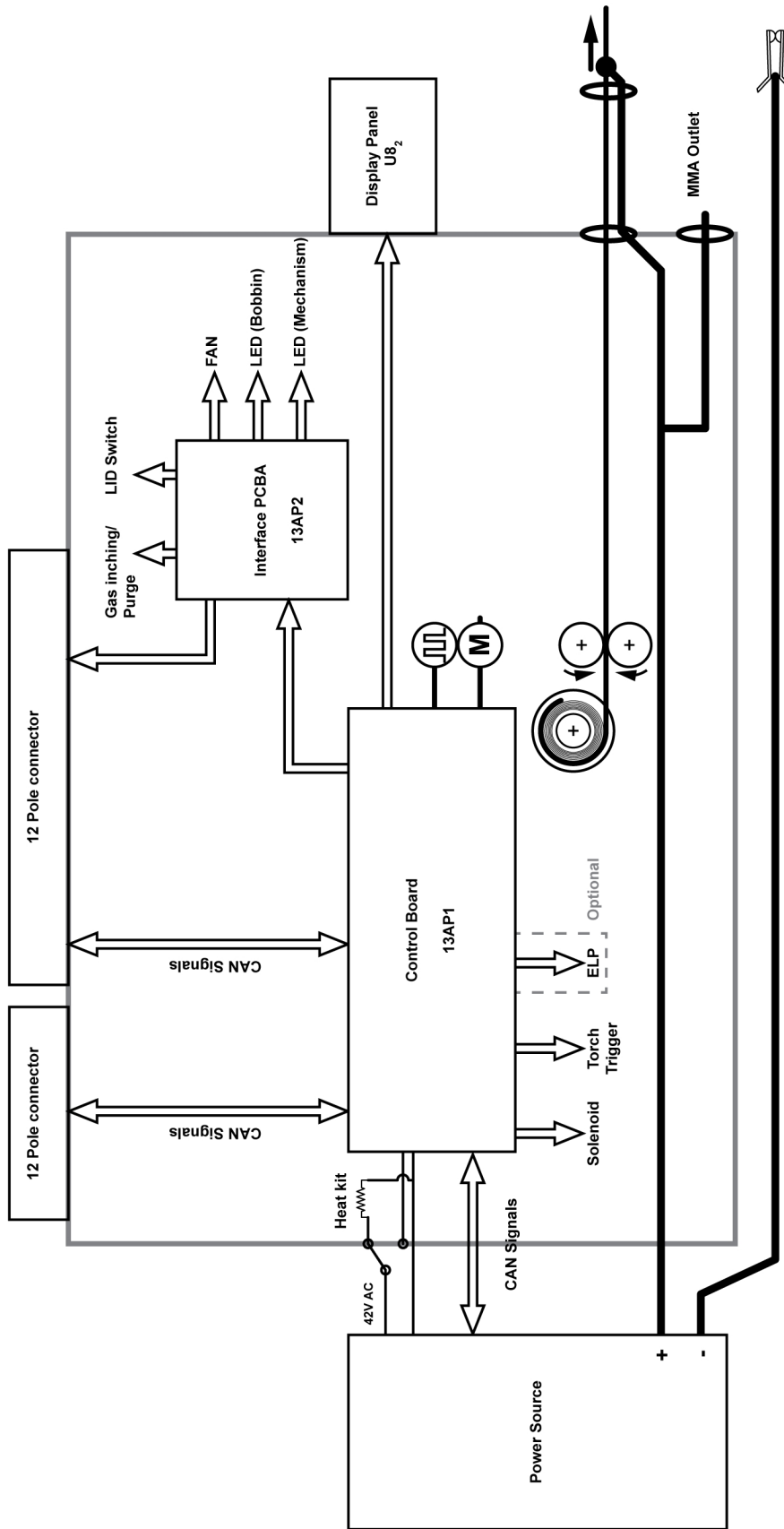

ORDERING NUMBERS







Ordering no.	Denomination	Notes
0445 800 896	Robust Feed U8 ₂ Offshore, Water, Tweco connector	CSA, U82 Plus included, flow meter, heater, MMA outlet, Water, ELP, 12 pole digital remote connector for U8 ₂ Plus
0445 800 900	Robust Feed U8 ₂ Push-Pull, Offshore, Water, Euro connector	CE, U8 ₂ Plus included, flow meter, heater, MMA outlet, Water, ELP, push-pull, Miggytrac/Railtrac, , 12 pole digital remote connector for U8 ₂ Plus, 23 pole analogue remote connector
0445 800 904	Robust Feed U8 ₂ Push-Pull, Offshore, Water, Tweco connector	CSA, U82 Plus included, flow meter, heater, MMA outlet, Water, ELP, push-pull, Miggytrac/Railtrac, 12 pole digital remote connector for U8 ₂ Plus, 12 pole digital remote connector for remote interface

Technical documentation is available on the Internet at: www.esab.com



WEAR PARTS



Fe, Ss and cored wire

Wire diameter (in.) (mm)	.023 0.6	.030 0.8	.040 0.9/1. 0	.045 1.2	.052 1.4	1/16 1.6	.070 1.8	5/64 2.0	 Feed roller
V-groove 	X	X							0445 850 001
		X	X						0445 850 002
			X						0445 850 003
			X	X					0445 850 004
				X					0445 850 005
					X	X			0445 850 006
								X	0445 850 007





Inlet wire guide 	Middle wire guide 	Outlet wire guide 
0445 822 001 (2 mm)	0446 080 882	0445 830 883 (Tweco) 0445 830 881 (Euro)

Cored wire – Different wire guides dependent on wire diameter!



Wire diameter (in.) (mm)	.040 0.9/1. 0	.045 1.2	.052 1.4	1/16 1.6	.070 1.8	5/64 2.0	3/32 2.4	 Feed roller
V-K-knurled 	X	X						0445 850 030
		X						0445 850 031
		X	X					0445 850 032
					X			0445 850 033
						X		0445 850 034
							X	0445 850 035
								X

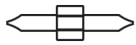

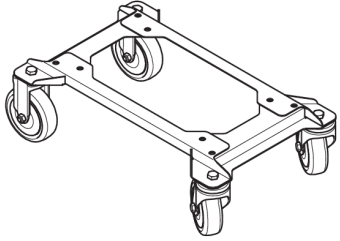
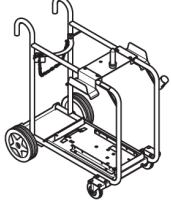
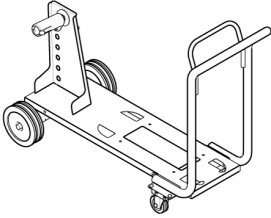
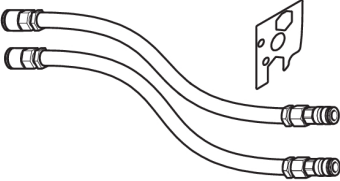
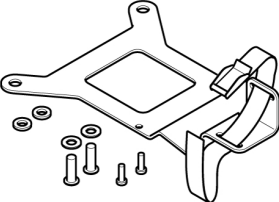

	Inlet wire guide 	Middle wire guide 	Outlet wire guide 
Wire diameter 0.040–1/16 in. 0.9–1.6 mm	0445 822 001 (2 mm)	0446 080 882	0445 830 883 (Tweco) 0445 830 881 (Euro)
Wire diameter 0.070–3/32 in. 1.8–2.4 mm	0445 822 002 (3 mm)	0446 080 883	0445 830 884 (Tweco) 0445 830 882 (Euro)

Al wire

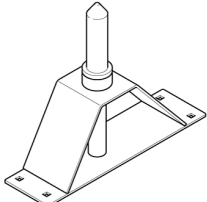
Wire diameter (in.) (mm)	.023 0.6	.030 0.8	.040 0.9/1. 0	.045 1.2	.052 1.4	1/16 1.6	.070 1.8	 Feed roller
U-groove 		X	X					0445 850 050
			X	X				0445 850 051
				X		X		0445 850 052
Inlet wire guide 	Middle wire guide 			Outlet wire guide 				
0445 822 001 (2 mm)	0446 080 881			0445 830 886 (Tweco)				
				0445 830 885 (Euro)				

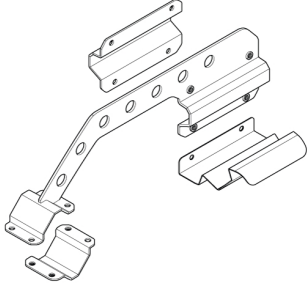
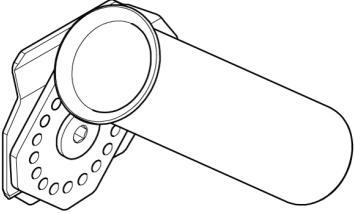
ACCESSORIES

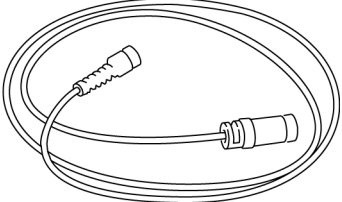
0446 081 880	Wheel kit	
0349 313 450	Trolley	
0349 313 700	Wire feeder trolley for 17.5 in (440 mm) coils	
0446 123 880	Liquid cooling kit	
0446 082 880	Torch strain relief	
F102 440 880	Quick connector Marathon Pac™	
0465 508 880	Guide pin extension kit For the feeder assembled with the wheel kit	

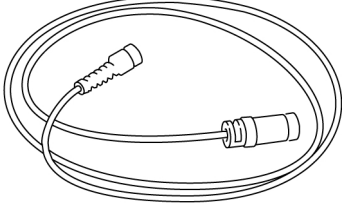
<p>0446 956 880</p>	<p>Boom adaptor kit including a stopper for RobustFeed door</p> <p>For assembly instructions, refer to the Boom adaptor assembly instruction manual</p>	
<p>0446 958 880</p>	<p>Torch holder</p> <p>For assembly on the RobustFeed</p> <p>For assembly instructions, refer to the Torch holder assembly instruction manual</p>	
<p>Analogue remotes compatible with 23 pole connectors</p>		
<p>0459 491 895</p>	<p>Remote control unit M1</p> <ul style="list-style-type: none"> • MIG/MAG: wire feed speed and voltage 	
<p>0459 553 880</p>	<p>Remote cable 8 pole – 23 pole, 16.5 ft (5 m)</p>	
<p>Digital remotes compatible with 12 pole connectors</p>		
<p>0459 491 880</p>	<p>Remote control unit MTA1 CAN</p> <ul style="list-style-type: none"> • MIG/MAG: wire feed speed and voltage • MMA: current and arc force • TIG: current, pulse and background current 	
<p>0459 491 882</p>	<p>Remote control unit M1 10 Prog CAN</p> <ul style="list-style-type: none"> • Choice of one of 10 programs • MIG/MAG: voltage deviation • TIG: and MMA current deviation 	
<p>0459 554 880</p>	<p>Remote cable CAN 4 pole – 12 pole, 16.5 ft (5 m)</p>	
<p>0459 554 980</p>	<p>Remote cable CAN 4 pole – 12 pole, 16.5 ft (5 m) HD</p>	

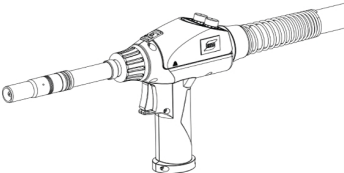
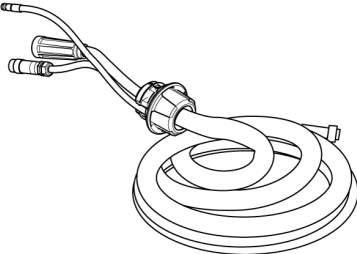
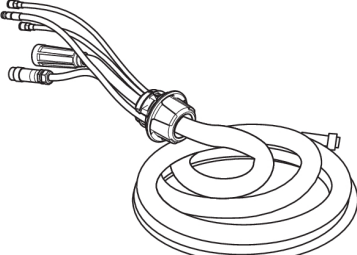
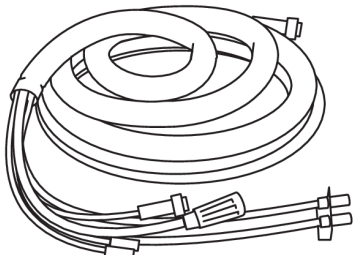
Push Pull welding torches compatible with 23 pole analogue connectors		
0700 025 304	MXH 315 PP, Gas cooled, 270 A at 60%, 2 knobs, 8 m	
0700 025 305	MXH 315 PP, Gas cooled, 270 A at 60%, 2 knobs, 12 m	
0700 025 307	MXH 420w PP, Water cooled, 400 A at 100%, 2 knobs, 8 m	
0700 025 308	MXH 420w PP, Water cooled, 400 A at 100%, 2 knobs, 12 m	
Interconnection cable with pre-assembled strain relief, Air cooled, 70 mm²:		
0446 255 880	2 m (7 ft.)	
0446 255 881	5 m (16 ft.)	
0446 255 882	10 m (33 ft.)	
0446 255 883	15 m (49 ft.)	
0446 255 884	20 m (66 ft.)	
0446 255 885	25 m (82 ft.)	
0446 255 886	35 m (115 ft.)	
Interconnection cable with pre-assembled strain relief, Liquid cooled, 70 mm²:		
0446 255 890	2 m (7 ft.)	
0446 255 891	5 m (16 ft.)	
0446 255 892	10 m (33 ft.)	
0446 255 893	15 m (49 ft.)	
0446 255 894	20 m (66 ft.)	
0446 255 895	25 m (82 ft.)	
0446 255 896	35 m (115 ft.)	
Interconnection cable without strain relief, Air cooled, 95 mm²:		
0459 528 960	1.7 m (7 ft.)	
0459 528 961	5 m (16 ft.)	
0459 528 962	10 m (33 ft.)	
0460 528 963	15 m (49 ft.)	
0460 528 964	25 m (82 ft.)	
0460 528 965	35 m (115 ft.)	

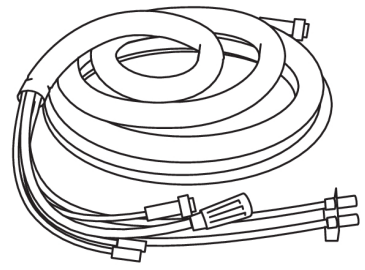
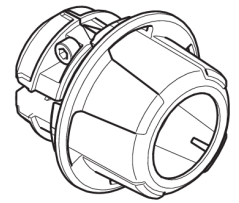
Interconnection cable without strain relief, Liquid cooled, 95 mm²:		
0459 528 970	1.7 m (7 ft.)	
0459 528 971	5 m (16 ft.)	
0459 528 972	10 m (33 ft.)	
0459 528 973	15 m (49 ft.)	
0459 528 974	25 m (82 ft.)	
0459 528 975	35 m (115 ft.)	
0446 050 881	Interconnection strain relief kit *(for update of cables without strain relief)	



A WORLD OF PRODUCTS AND SOLUTIONS.



For contact information visit <http://esab.com>

ESAB AB, Lindholmsallén 9, Box 8004, 402 77 Gothenburg, Sweden, Phone +46 (0) 31 50 90 00

manuals.esab.com

